



Torque Motor

Technical Information





Linear Motor Stage

Automated transport / AOI application / Precision / Semiconductor

- With Iron Core
- Ironless Type
- Linear Turbo LMT
- Planar Servo Motor
- Air Bearing Platform
- X-Y Stage • Gantry Systems
- Single-Axis Linear Motor Stage



Linear Motor

Machine tool / Touch panel industry / Semiconductor industry / Laser manufacturing machine / Glass cutting machine

- Iron Core linear motor-LMFA series, LMSA series, LMSC series
- Ironless linear motor-LMC series, LMT series



Torque Motor & Direct Drive Motor

Machine Tools

- Torque Motor-- TM-2/IM-2, TMRW Series

Inspection / Testing Equipment / Robot

- Direct Drive Motor-- DMS, DMY, DMN, DMT Series



AC Servo Motor & Drive

Semiconductor / Packaging machine / SMT / Food industry / LCD

- Drives-D1, D2T/D2T-LM, E1
- Motors-50W-2000W



Linear Actuator

Hospital bed / Automatic window / Home care facility / Riveting / Press-fitting / Surface checks / Bending

- Servo Actuator-LAA series
- LAM series
- LAS series
- LAN series
- LAC series



Positioning Measurement System

Cutting machines / Traditional gantry milling machines / Programmable drilling machines

- High Resolution
- Signal Translator
- High-precision Enclosed
- High Efficiency Counter



Multi-Axis Robot

Pick-and-place / Assembly / Array and packaging / Semiconductor / Electro-Optical industry / Automotive industry / Food industry

- Articulated Robot
- Delta Robot
- SCARA Robot
- Wafer Robot
- Electric Gripper
- Integrated Electric Gripper
- Rotary Joint



Single-Axis Robot

Precision / Semiconductor / Medical / FPD

- KK, SK
- KS, KA
- KU, KE, KC



Torque Motor Rotary Table

Medical / Automotive industry / Machine tools / Machinery industry

- RAB Series
- RAS Series
- RCV Series
- RCH Series



Ballscrew

Precision Ground / Rolled

- Super S series
- Super T series
- Mini Roller
- Ecological & Economical lubrication Module E2
- Rotating Nut (R1)
- Energy-Saving & Thermal-Controlling (C1)
- Heavy Load Series (RD)
- Ball Spline



Linear Guideway

Automation / Semiconductor / Medical







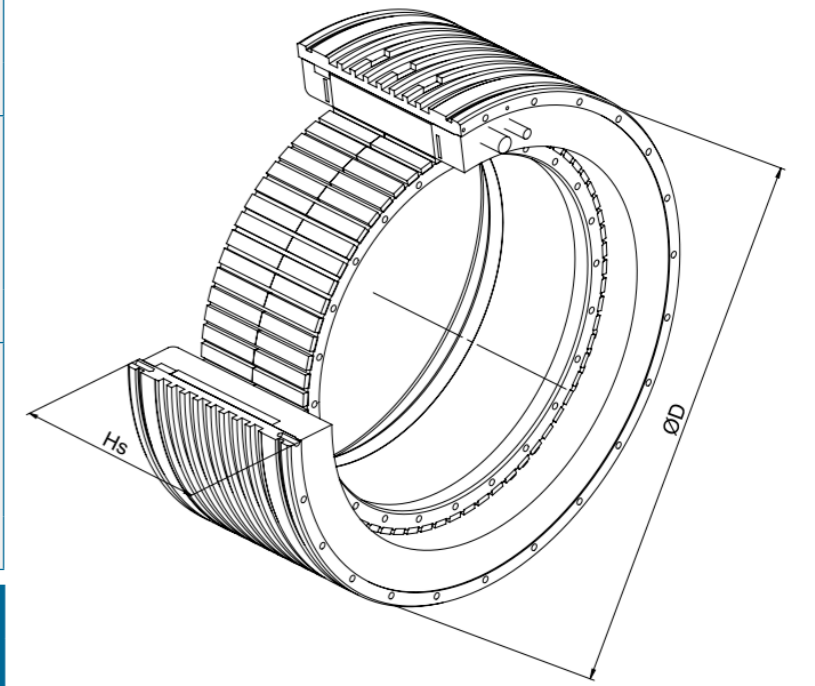













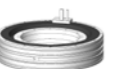

- Ball Type--HG, EG, WE, MG, CG
- Quiet Type--QH, QE, QW, QR
- Other--RG, E2, PG, SE, RC

TM-2 Configurator Chart

	Peak Torque (Nm)	45	75	96	105	160	172	150	224	225	286	320	400	480	561	780	Page	
	Continuous Torque @ W.C. (Nm)	27	45	50	63	83	90	90	116	135	151	166	211	249	295	411		
Torque Motor	ØD (mm)	Ø160	 TM-2-13-LA0 TM-2-13-SA0	 TM-2-15-LA0 TM-2-15-SA0		 TM-2-17-LA0 TM-2-17-SA0			 TM-2-1A-LA0 TM-2-1A-SA0	 TM-2-1F-LA0 TM-2-1F-SA0							06	
	Hs (mm)		70	90		110			140	190								
	ØD (mm)	Ø198			 TM-2-23-PA0 TM-2-23-PB0		 TM-2-25-PA0 TM-2-25-PB0			 TM-2-27-PA0 TM-2-27-PB0		 TM-2-2A-PA0 TM-2-2A-PB0		 TM-2-2F-PA0 TM-2-2F-PB0				08
	Hs (mm)				80	100			120			150		200				
	ØD (mm)	Ø230					 TM-2-43-LA0 TM-2-43-SA0				 TM-2-45-LA0 TM-2-45-SA0		 TM-2-47-LA0 TM-2-47-SA0		 TM-2-4A-SA0 TM-2-4A-PB0	 TM-2-4F-PA0 TM-2-4F-PB0		10
	Hs (mm)						70				90		110		140	190		
Torque Motor	Peak Torque (Nm)	345	570	510	800	840	860	1140	1200	1410	1710	1720	1980	2580	2820	4240	Page	
	Continuous Torque @ W.C. (Nm)	175	284	272	400	415	453	569	633	700	853	905	990	1358	1410	2120		
	ØD (mm)	Ø310	 TM-2-73-LB0 TM-2-73-PB0	 TM-2-75-PB0 TM-2-75-SB0		 TM-2-77-PB0 TM-2-77-SB0			 TM-2-7A-PB0 TM-2-7A-SB0			 TM-2-7F-PB0 TM-2-7F-SB0						12
	Hs (mm)		80	100		120			150			200						
	ØD (mm)	Ø385			 TM-2-A3-PB0 TM-2-A3-PC0		 TM-2-A5-PB0 TM-2-A5-PC0		 TM-2-A7-PC0 TM-2-A7-PF0		 TM-2-AA-PC0 TM-2-AA-PF0		 TM-2-AF-PC0 TM-2-AF-PF0					14
	Hs (mm)				90		110		130			160		210				
ØD (mm)	Ø485				 TM-2-D3-SB0 TM-2-D3-SD0				 TM-2-D5-SB0 TM-2-D5-SD0			 TM-2-D7-SB0 TM-2-D7-SD0		 TM-2-DA-SB0 TM-2-DA-SD0	 TM-2-DF-SB0 TM-2-DF-SD0		16	
Hs (mm)					90				110			130		160	210			
Torque Motor	Peak Torque (Nm)												2000	2800	4000	6000	Page	
	Continuous Torque @ W.C. (Nm)												1125	1575	2250	3375		
	ØD (mm)	Ø565											 TM-2-G5-SB0 TM-2-G5-SD0	 TM-2-G7-SB0 TM-2-G7-SD0	 TM-2-GA-SB0 TM-2-GA-SD0	 TM-2-GF-SB0 TM-2-GF-SD0	18	
	Hs (mm)												110	130	160	210		

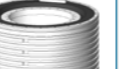

IM-2 Configurator Chart

IM Motor	Peak Torque (Nm)	76	128	172	179	286	256	393	384	561	780	Page	
	Continuous Torque @ W.C. (Nm)	49.8	83	90	116.2	151	168	207	250	295	411		
	Max. Speed @ (Field weakening) (RPM)	5000	3200	1500	2300	1000	3200	1500	2150	1500	1000		
		5450	5450	3000	4600	3000	5450	3000	4100	3000	2500		
∅D (mm)	∅198	 IM-2-23-PA0 IM-2-23-PB0	 IM-2-25-PA0 IM-2-25-PB0	 IM-2-27-PA0 IM-2-27-PB0	 IM-2-2A-PA0 IM-2-2A-PB0	 IM-2-2F-PA0 IM-2-2F-PB0						22	
Hs (mm)		80	100		120		150		200				
∅D (mm)	∅230			 IM-2-43-LA0 IM-2-43-SA0	 IM-2-45-LA0 IM-2-45-SA0	 IM-2-47-LA0 IM-2-47-SB0	 IM-2-4A-LA0 IM-2-4A-SB0	 IM-2-4F-LA0 IM-2-4F-SB0				24	
Hs (mm)				70	90		110		140	190			
IM Motor	Peak Torque (Nm)	298	490	495	690	810	990	1140	1485	1630	2440	Page	
	Continuous Torque @ W.C. (Nm)	167	320	279	390	540	557	756	836	1080	1620		
	Max. Speed @ (Field weakening) (RPM)	1500	1200	2500	1700	1600	1250	1200	1700	800	1050		
		2730	1700	2730	2730	1850	2400	1850	2730	1600	1600		
∅D (mm)	∅310	 IM-2-73-SA0 IM-2-73-SB0	 IM-2-75-SB0 IM-2-75-SD0	 IM-2-77-SB0 IM-2-77-SD0	 IM-2-7A-SB0 IM-2-7A-SD0	 IM-2-7F-SB0 IM-2-7F-SD0						26	
Hs (mm)		80	100	120		150		200					
∅D (mm)	∅385		 IM-2-A3-PB0 IM-2-A3-PC0		 IM-2-A5-PC0 IM-2-A5-PF0	 IM-2-A7-PC0 IM-2-A7-PF0	 IM-2-AA-PC0 IM-2-AA-PF0	 IM-2-AF-PF0 IM-2-AF-SF0				28	
Hs (mm)			90		110		130		160	210			
IM Motor	Peak Torque (Nm)							1900	2660	3800	5700	Page	
	Continuous Torque @ W.C. (Nm)							1080	1510	2160	3240		
	Max. Speed @ (Field weakening) (RPM)								600	400	300		200
									1200	800	600		400
∅D (mm)	∅565						 IM-2-G5-SB0 IM-2-G5-SD0	 IM-2-G7-SB0 IM-2-G7-SD0	 IM-2-GA-SB0 IM-2-GA-SD0	 IM-2-GF-SB0 IM-2-GF-SH0	30		
Hs (mm)							110	130	160	210			

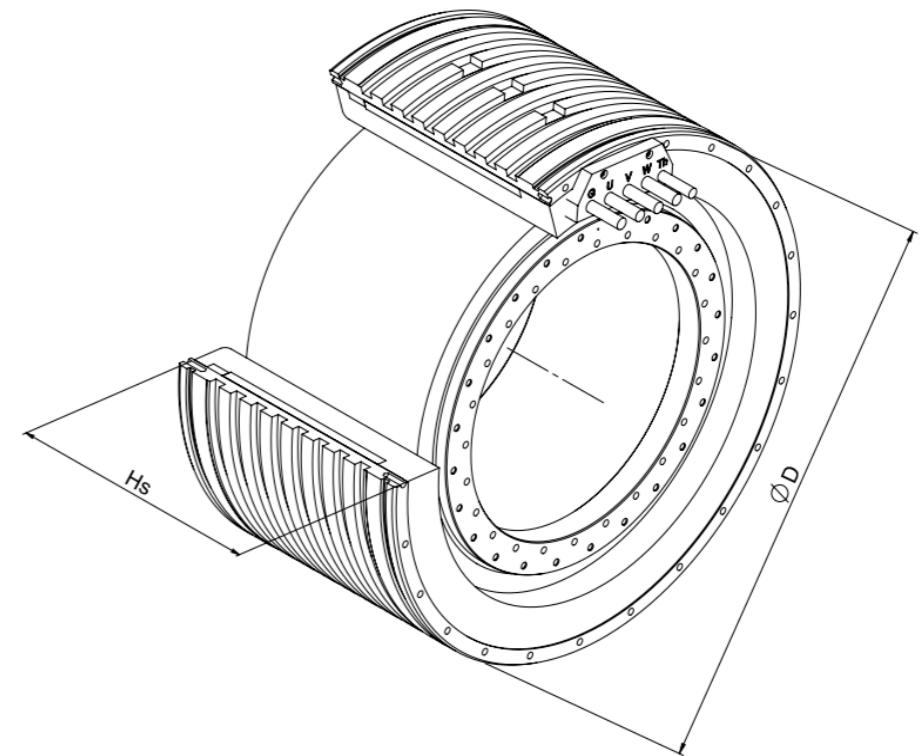

Contents

Torque Motor

Product Overview 04

1.TM-2 Torque Motor 05

1.1 TM-2-1x	06
1.1.1 TM-2-1x Dimensions	06
1.1.2 TM-2-1x Series T-N Curves.....	07
1.2 TM-2-2x	08
1.2.1 TM-2-2x Dimensions	08
1.2.2 TM-2-2x Series T-N Curves.....	09
1.3 TM-2-4x	10
1.3.1 TM-2-4x Dimensions	10
1.3.2 TM-2-4x Series T-N Curves.....	11
1.4 TM-2-7x	12
1.4.1 TM-2-7x Dimensions	12
1.4.2 TM-2-7x Series T-N Curves.....	13
1.5 TM-2-Ax	14
1.5.1 TM-2-Ax Dimensions	14
1.5.2 TM-2-Ax Series T-N Curves.....	15
1.6 TM-2-Dx	16
1.6.1 TM-2-Dx Dimensions	16
1.6.2 TM-2-Dx Series T-N Curves.....	17
1.7 TM-2-Gx	18
1.7.1 TM-2-Gx Dimensions	18
1.7.2 TM-2-Gx Series T-N Curves.....	19

2.IM-2 Motor 21

2.1 IM-2-2x	22
2.1.1 IM-2-2x Dimensions	22
2.1.2 IM-2-2x Series T-N Curves.....	23
2.2 IM-2-4x	24
2.2.1 IM-2-4x Dimensions	24
2.2.2 IM-2-4x Series T-N Curves.....	25
2.3 IM-2-7x	26
2.3.1 IM-2-7x Dimensions	26
2.3.2 IM-2-7x Series T-N Curves.....	27
2.4 IM-2-Ax	28
2.4.1 IM-2-Ax Dimensions	28
2.4.2 IM-2-Ax Series T-N Curves.....	29
2.4 IM-2-Gx	30
2.4.1 IM-2-Gx Dimensions	30
2.4.2 IM-2-Gx Series T-N Curves.....	31

3.Appendix 32

Appendix A: Torque Motor Selection	32
Appendix B: Glossary	36
Appendix C: Environment	39
Appendix D: Motor Inquiry Form	40

Product Overview

Torque motor adopts permanent magnet synchronous brushless design, which increases the efficiency and generates large torque output. Unlike servo motor with reduction mechanism, torque motor can directly connect to the load and output torque. The advantages are listed as follows.

1. Easy for design

- a. Large hollow shaft – Large hollow shaft rotor reduces the difficulty of design. Cables can be easily organized, and various parts can all be hidden in it.
- b. Low parts count – Directly connecting to the load can reduce the number of transition parts and further improve the reliability.
- c. Compact – The characteristics of large hollow shaft and direct connection make the mechanism design more compact.



2. Reduce the cost

- a. Without reduction mechanism – Reduce installation difficulties and maintenance cost.
- b. Without wear parts – Significantly reduce downtime and maintenance time. Production can be continuously performed.
- c. Long life – Without wear and reduction mechanism, the life of machine is greatly improved.



3. Improve the performance

- a. High dynamic characteristics – Without the transmission delay such as elastic connection, backlash and friction, it provides the best motion characteristics.
- b. Low cogging torque – Multiple polarities with the optimized motor design of HIWIN reduce the cogging torque during operation.
- c. Low moment of inertia – Large hollow shaft rotor reduces the load.
- d. High accuracy – Directly connecting to the load makes the position feedback more accurate.



1. TM-2 Torque Motor

Since reduction mechanism is not required, TM-2 series can be quickly installed to the equipment, especially suitable for machine tools. As the new generation of TMRW series, TM-2 series provides larger torque and lower cogging torque. With the same size and the same installation interface, when the liquid cooling system is used to dissipate heat, TM-2 series has better performance. Besides, TM-2 series has larger continuous torque and lowers the operating temperature of motor. To avoid the motor from accumulating too much energy during operation, all TM-2 torque motors are equipped with temperature sensors. Even if the motor carries extreme load, it will be protected from damage.

Key Features of the TM-2 Torque Motor:

- High continuous and peak torque
- High dynamics, high efficiency
- Wear-free operation, maintenance-free
- Built-in temperature sensor
- Low cogging torque

Typical applications:

- Machine tools
- Rotary tables

■ Model Numbers for TM-2 Series

Motor Specification	Temp. Sensor	Cable Output	Reserved Code
TM - 2 - 1 3 - L A 0 - 0 - 20 V - 0 0			
<p>Series: TM-2: Torque Motor</p> <p>External Diameter of Stator : 1: Ø160mm 2: Ø198mm 4: Ø230mm 7: Ø310mm A: Ø385mm D: Ø485mm G: Ø565mm</p> <p>Rotor (Magnet) Height : 3: 30mm 5: 50mm 7: 70mm A: 100mm F: 150mm</p> <p>Torque / Speed Characteristics: Refer to motor datasheet</p> <p>Temperature Sensor Configuration : 0: PTC100+PTC130+Pt1000 (Standard) 1: PTC100+PTC130+Pt1000x3</p> <p>Cable Output Style: 20: 2.0m (Standard) 05: 0.5m 10: 1.0m</p> <p>Cable Output Style: S: Straight output V: Straight output with cable clamp A: Straight output with cable gland H: 90° output in tangent direction with cable clamp (temp. cable straight output) P: All cable separate with cable clamp (straight output)</p> <p>Reserved: 00: Standard (without bridge) 03: Bridge on cable side</p>			

1.1 TM-2-1x

1.1.1 TM-2-1x Dimensions

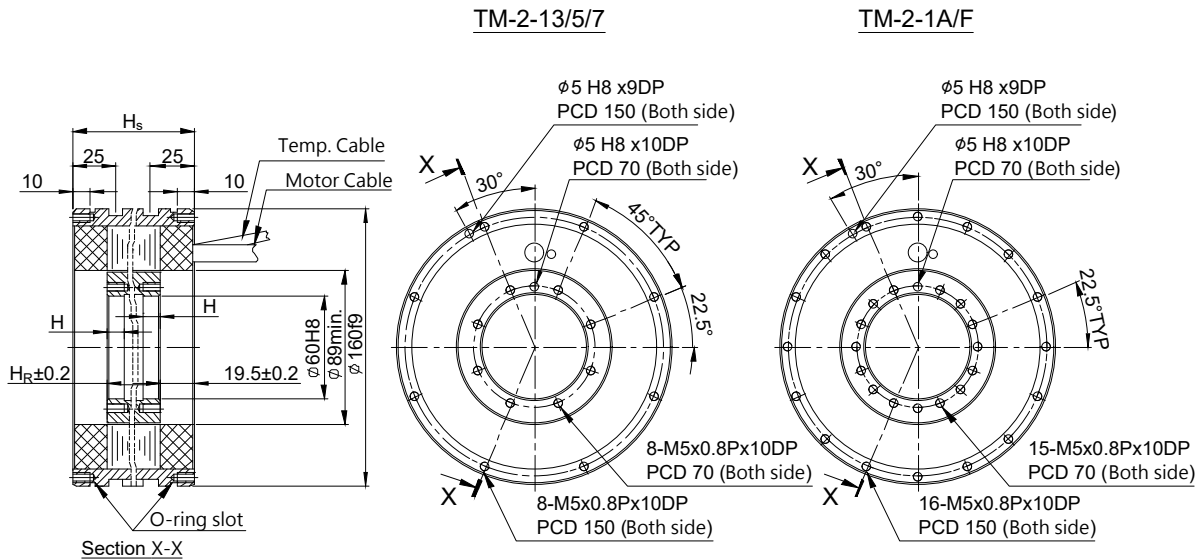

TM-2-1x Specifications

	Symbol	Unit	TM-2-13-LA0	TM-2-13-SA0	TM-2-15-LA0	TM-2-15-SA0	TM-2-17-LA0	TM-2-17-SA0	TM-2-1A-LA0	TM-2-1A-SA0	TM-2-1F-LA0	TM-2-1F-SA0
Continuous torque (WC)	T_{cw}	Nm	27	27	45	45	63	63	90	90	135	135
Continuous current (WC)	I_{cw}	A_{rms}	10.3	22.3	10.3	22.3	10.3	22.3	10.3	22.3	10.3	22.3
Stall torque (WC)	T_{sw}	Nm	22	22	37	37	52	52	74	74	111	111
Stall current (WC)	I_{sw}	A_{rms}	8.2	17.8	8.2	17.8	8.2	17.8	8.2	17.8	8.2	17.8
Peak torque (1s.)	T_p	Nm	45	45	75	75	105	105	150	150	225	225
Peak current (1s.)	I_p	A_{rms}	20	43.4	20	43.4	20	43.4	20	43.4	20	43.4
Torque constant	K_t	Nm/A_{rms}	2.86	1.32	4.76	2.18	6.67	3.05	9.53	4.36	14.29	6.55
Electrical time constant	T_e	ms	4.9	5.1	4.9	4.9	4.9	5.1	4.9	4.9	4.9	5
Resistance (line to line at 25°C)	R_{25}	Ω	3.5	0.7	5.1	1.1	6.8	1.4	9.2	2	13.3	2.8
Inductance (line to line)	L	mH	17.1	3.6	25.2	5.4	33.3	7.1	45.5	9.7	65.8	14
Number of poles	$2p$		22									
Back emf constant (line to line)	K_v	$V_{rms}/rad/s$	1.65	0.76	2.75	1.26	3.85	1.76	5.5	2.52	8.25	3.78
Motor constant (at 25°C)	K_m	Nm/\sqrt{W}	1.25	1.26	1.72	1.68	2.09	2.09	2.57	2.49	3.2	3.16
Thermal resistance (WC)	R_{thw}	K/W	0.189	0.201	0.129	0.128	0.097	0.101	0.072	0.07	0.05	0.05
Thermal sensor			PTC100+PTC130+Pt1000									
Max. DC BUS		V_{DC}	750									
Inertia of rotor	J	kgm^2	0.001	0.001	0.0016	0.0016	0.0023	0.0023	0.0033	0.0033	0.0049	0.0049
Max. speed at conti. Torque (WC)		rpm	1482	3338	913	2080	646	1510	437	1049	268	686
Max. speed at Peak Torque		rpm	935	2138	585	1362	410	1001	268	695	145	448
Rated speed ⁽¹⁾	ω_n	rpm	818	818	818	818	646	818	437	818	268	686
Mass of rotor	M_r	kg	0.7	0.7	1.2	1.2	1.6	1.6	2.3	2.3	3.5	3.5
Mass of stator	M_s	kg	4.5	4.5	6.4	6.4	8	8	11.1	11.1	16	16
Height of stator	H_s	mm	70	70	90	90	110	110	140	140	190	190
Height of rotor	H_r	mm	31	31	51	51	71	71	101	101	151	151
Height	H	mm	10	10	15	15	15	15	15	15	15	15

Note : WC : water cooled

*All the specifications in the table are in $\pm 10\%$ of tolerance except dimensions.

¹⁾ The rated speed is the maximum speed which the motor can run continuously without rest.

More information please refer to Appendix B:Glossary.

1.1.2 TM-2-1x Series T-N Curves

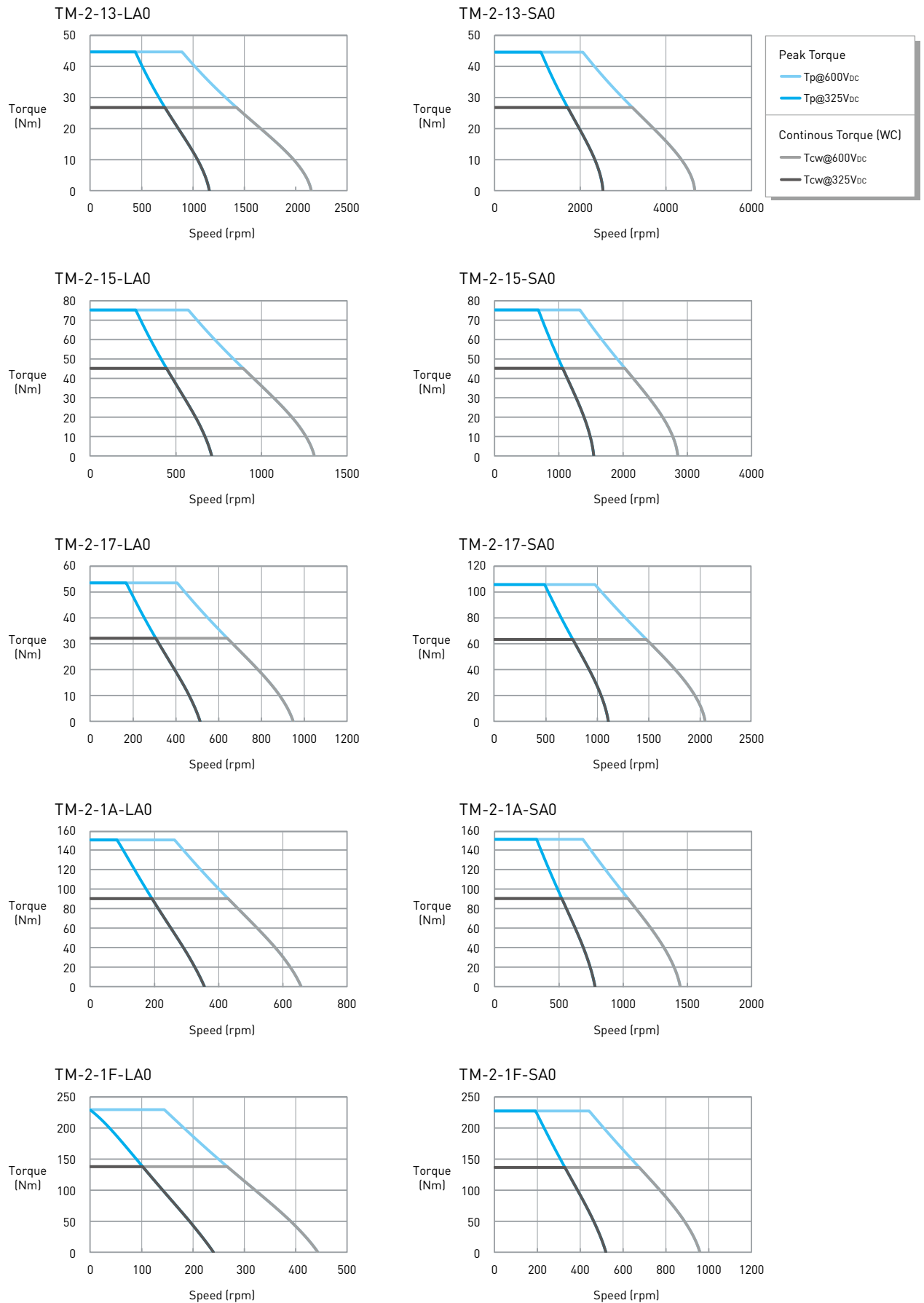

1.2 TM-2-2x

1.2.1 TM-2-2x Dimensions

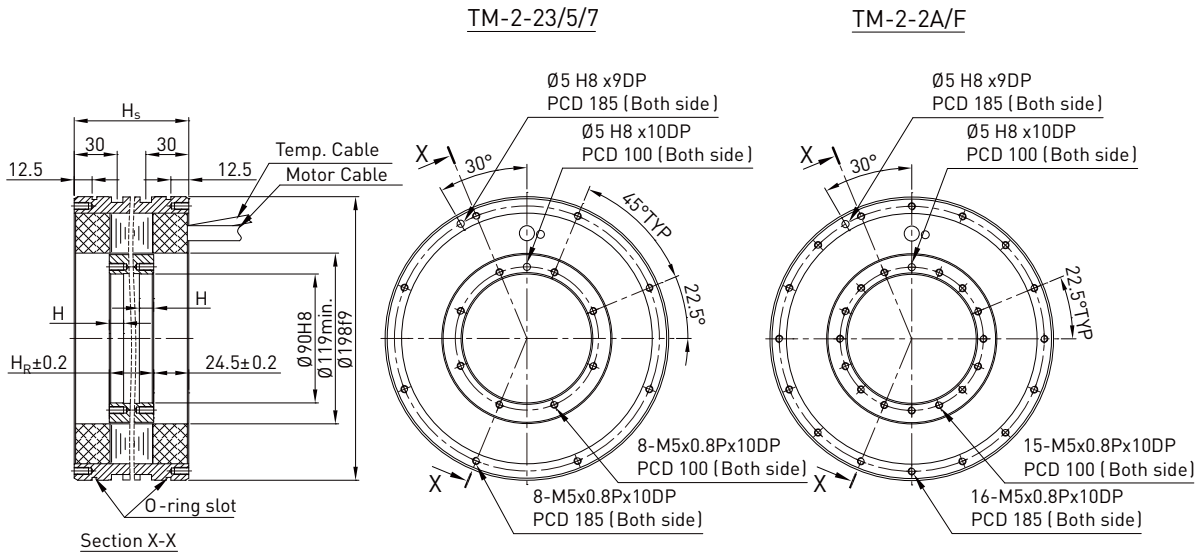

TM-2-2x Specifications

	Symbol	Unit	TM-2-23-PA0	TM-2-23-PB0	TM-2-25-PA0	TM-2-25-PB0	TM-2-27-PA0	TM-2-27-PB0	TM-2-2A-PA0	TM-2-2A-PB0	TM-2-2F-PA0	TM-2-2F-PB0
Continuous torque (WC)	T_{cw}	Nm	50	50	83	83	116	116	166	166	249	249
Continuous current (WC)	I_{cw}	A_{rms}	10.2	20.4	10.2	20.4	10.2	20.4	10.2	20.4	10.2	20.4
Stall torque (WC)	T_{sw}	Nm	41	41	68	68	95	95	136	135	204	203
Stall current (WC)	I_{sw}	A_{rms}	8.2	16.3	8.2	16.3	8.2	16.3	8.2	16.3	8.2	16.3
Peak torque (1s.)	T_p	Nm	96	96	160	160	224	224	320	320	480	480
Peak current (1s.)	I_p	A_{rms}	25.5	51	25.5	51	25.5	51	25.5	51	25.5	51
Torque constant	K_t	Nm/A_{rms}	5.02	2.42	8.31	4.16	11.6	5.89	16.63	8.31	24.94	12.47
Electrical time constant	T_e	ms	7.3	7.1	7.2	7.2	7.2	7.3	7.2	7.1	7.2	7.2
Resistance (line to line at 25°C)	R_{25}	Ω	3.5	0.9	5.2	1.3	6.9	1.7	9.4	2.4	13.6	3.4
Inductance (line to line)	L	mH	25.5	6.4	37.6	9.4	49.7	12.4	68	17	98.2	24.6
Number of poles	2p		22									
Back emf constant (line to line)	K_v	$V_{rms}/rad/s$	2.9	1.4	4.8	2.4	6.7	3.4	9.6	4.8	14.4	7.2
Motor constant (at 25°C)	K_m	Nm/\sqrt{W}	2.17	2.14	2.98	2.98	3.62	3.65	4.43	4.38	5.52	5.52
Thermal resistance (WC)	R_{thw}	K/W	0.192	0.187	0.129	0.129	0.098	0.099	0.072	0.07	0.049	0.049
Thermal sensor			PTC100+PTC130+Pt1000									
Max. DC BUS		V_{DC}	750									
Inertia of rotor	J	kgm^2	0.001	0.001	0.0016	0.0016	0.0023	0.0023	0.0033	0.0033	0.0049	0.0049
Max. speed at conti. Torque (WC)		rpm	911	1911	556	1167	392	832	263	579	160	374
Max. speed at Peak Torque		rpm	489	1034	301	663	206	479	127	328	56	203
Rated speed ⁽¹⁾	ω_n	rpm	818	818	556	818	392	818	263	579	160	374
Mass of rotor	M_r	kg	1	1	1.7	1.7	2.3	2.3	3.3	3.3	5	5
Mass of stator	M_s	kg	6.9	6.9	10.5	10.5	12	12	16.7	16.7	23.9	23.9
Height of stator	H_s	mm	80	80	100	100	120	120	150	150	200	200
Height of rotor	H_r	mm	31	31	51	51	71	71	101	101	151	151
Height	H	mm	10	10	15	15	15	15	15	15	15	15

Note : WC : water cooled

*All the specifications in the table are in $\pm 10\%$ of tolerance except dimensions.

¹⁾ The rated speed is the maximum speed which the motor can run continuously without rest.

More information please refer to Appendix B:Glossary.

1.2.2 TM-2-2x Series T-N Curves

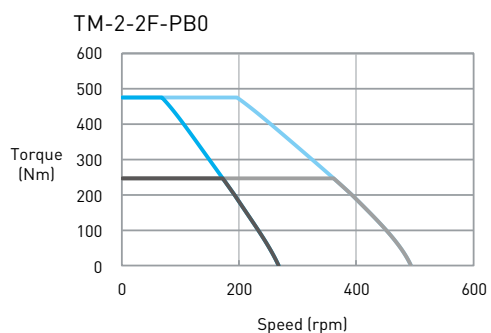
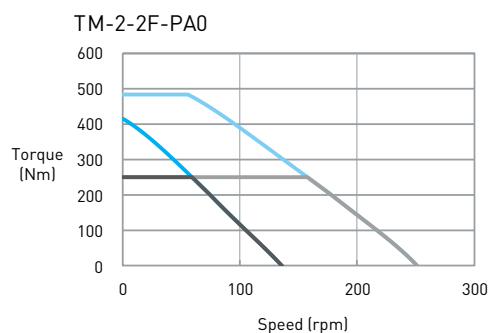
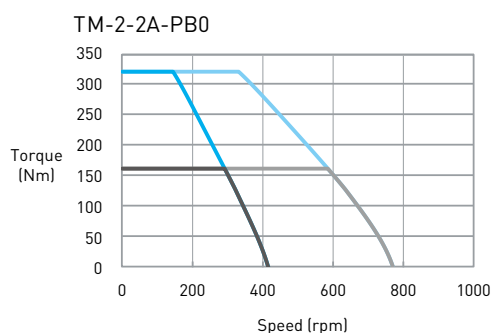
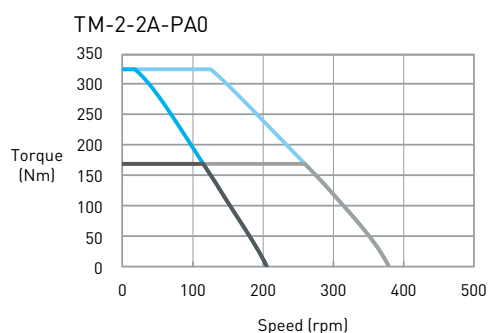
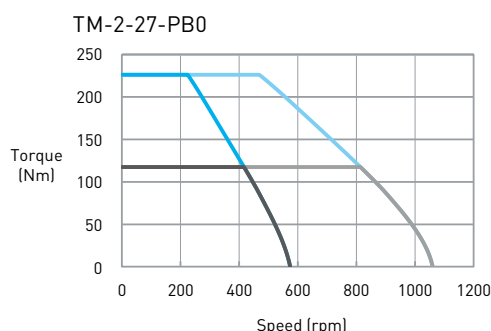
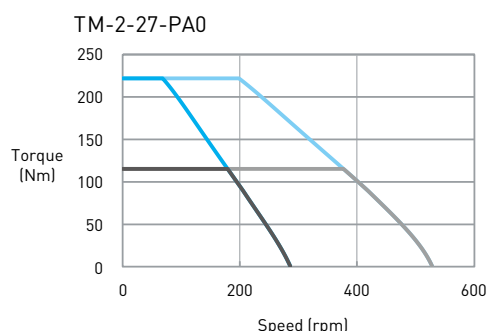
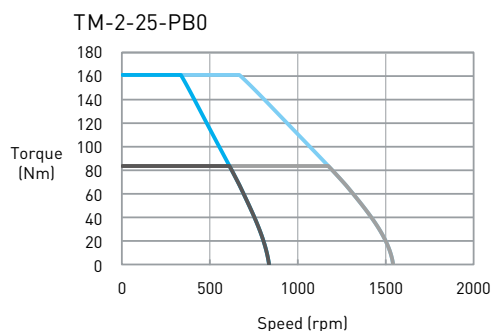
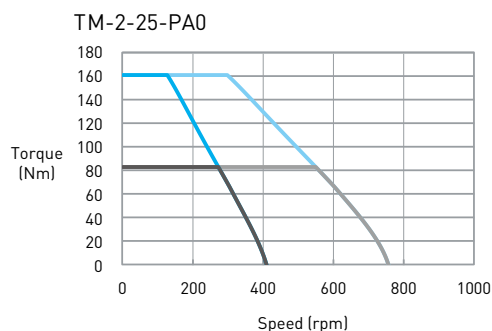
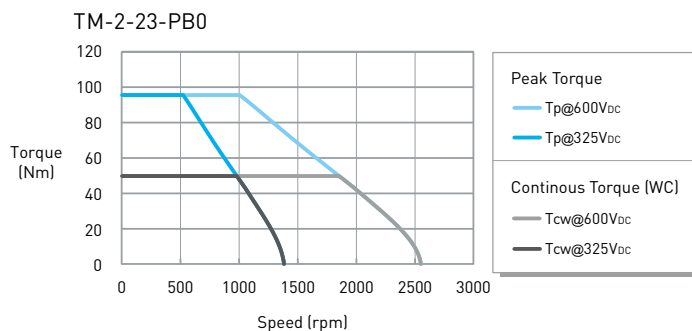
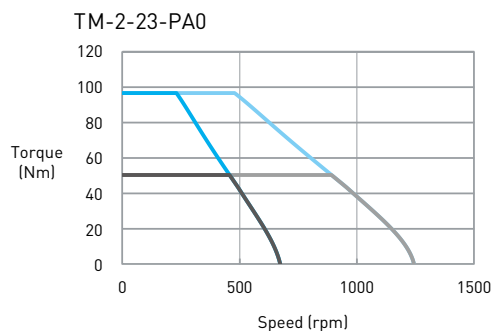

1.3 TM-2-4x

1.3.1 TM-2-4x Dimensions

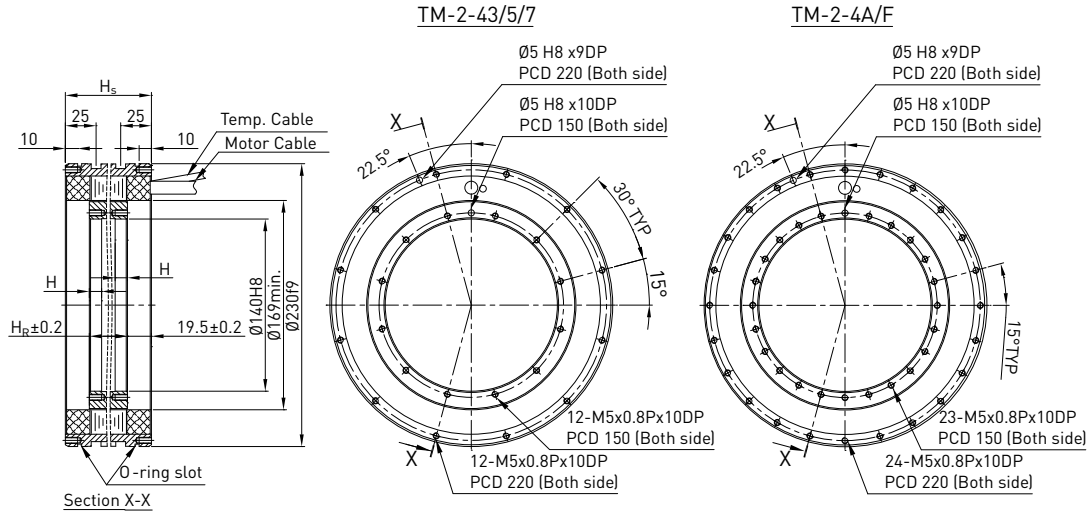

TM-2-4x Specifications

	Symbol	Unit	TM-2-43-LA0	TM-2-43-SA0	TM-2-45-LA0	TM-2-45-SA0	TM-2-47-LA0	TM-2-47-SA0	TM-2-4A-SA0	TM-2-4A-PB0	TM-2-4F-PA0	TM-2-4F-PB0
Continuous torque (WC)	T_{cw}	Nm	90	89	151	148	211	207	295	274	411	411
Continuous current (WC)	I_{cw}	A_{rms}	11.4	24.9	11.4	24.9	11.4	24.9	24.9	36	18	36
Stall torque (WC)	T_{sw}	Nm	73	72	122	120	171	168	239	222	334	334
Stall current (WC)	I_{sw}	A_{rms}	9.1	19.9	9.1	19.9	9.1	19.9	19.9	28.8	14.4	28.8
Peak torque (1s.)	T_p	Nm	172	168	286	281	400	393	561	520	780	780
Peak current (1s.)	I_p	A_{rms}	23.7	52	23.7	52	23.7	52	52	75	37.5	75
Torque constant	K_t	Nm/A_{rms}	8.31	3.81	13.86	6.41	19.4	8.66	12.47	7.97	23.9	11.95
Electrical time constant	T_e	ms	2.8	2.8	2.8	2.8	2.8	2.8	2.8	2.8	2.8	2.8
Resistance (line to line at 25°C)	R_{25}	Ω	5.6	1.2	8.3	1.72	11	2.3	3.1	1.5	8.7	2.17
Inductance (line to line)	L	mH	15.8	3.3	23.3	4.84	30.8	6.41	8.75	4.2	24.3	6.08
Number of poles	2p		44									
Back emf constant (line to line)	K_v	$V_{rms}/rad/s$	4.8	2.2	8	3.7	11.2	5	7.2	4.6	13.8	6.9
Motor constant (at 25°C)	K_m	Nm/\sqrt{W}	2.86	2.84	3.89	3.93	4.71	4.6	5.74	5.27	6.59	6.6
Thermal resistance (WC)	R_{thw}	K/W	0.096	0.094	0.065	0.066	0.049	0.049	0.036	0.036	0.025	0.025
Thermal sensor			PTC100+PTC130+Pt1000									
Max. DC BUS		V_{DC}	750									
Inertia of rotor	J	kgm^2	0.0085	0.0085	0.014	0.014	0.022	0.022	0.029	0.029	0.045	0.045
Max. speed at conti. Torque (WC)		rpm	556	1295	323	782	217	565	381	614	162	392
Max. speed at Peak Torque		rpm	352	862	196	533	118	378	247	410	72	251
Rated speed ¹⁾	ω_n	rpm	409	409	323	409	217	409	381	409	162	392
Mass of rotor	M_r	kg	1.5	1.5	2.6	2.6	3.5	3.5	5	5	7.6	7.6
Mass of stator	M_s	kg	6.5	6.5	9	9	11.2	11.2	15	15	22.2	22.2
Height of stator	H_s	mm	70	70	90	90	110	110	140	140	190	190
Height of rotor	H_r	mm	31	31	51	51	71	71	101	101	151	151
Height	H	mm	10	10	15	15	15	15	15	15	15	15

Note : WC : water cooled

*All the specifications in the table are in $\pm 10\%$ of tolerance except dimensions.

¹⁾ The rated speed is the maximum speed which the motor can run continuously without rest.

More information please refer to Appendix B:Glossary.

1.3.2 TM-2-4x Series T-N Curves

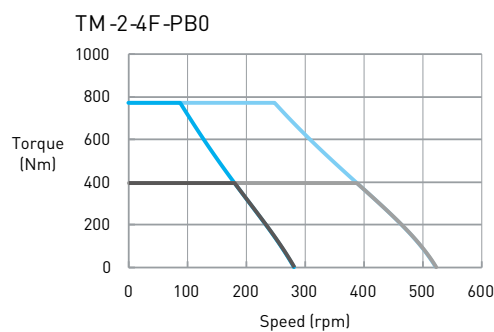
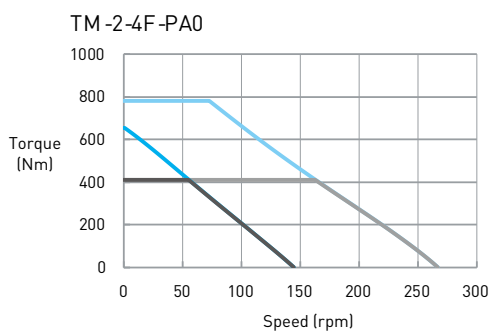
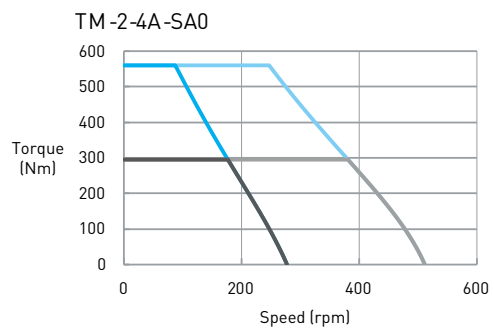
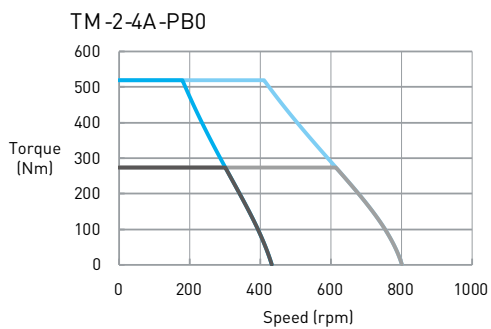
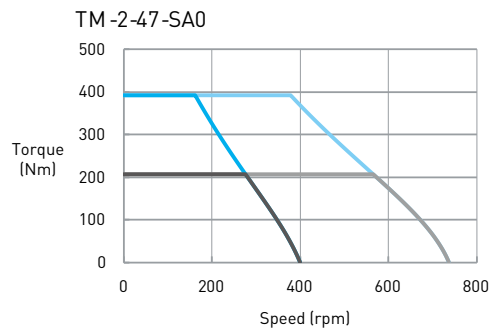
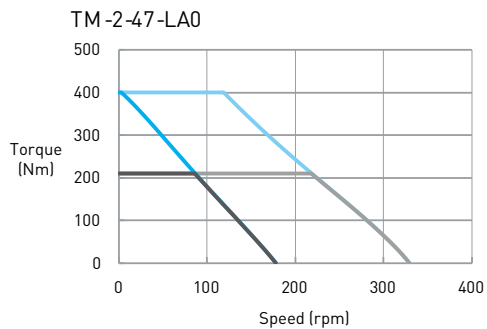
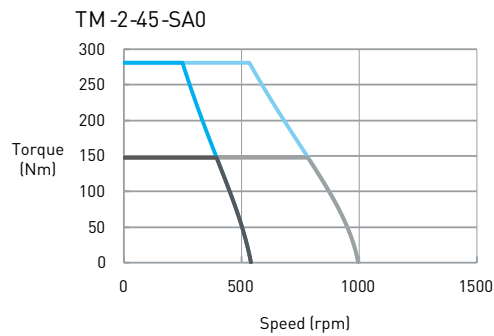
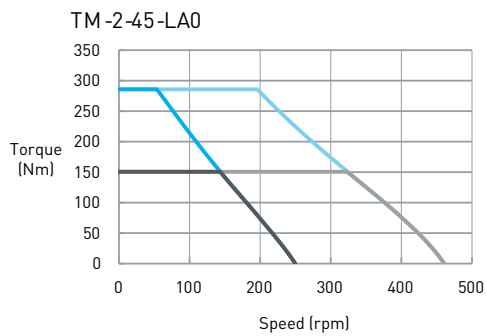
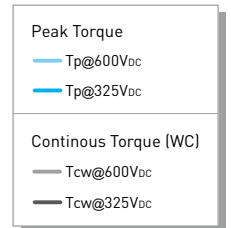
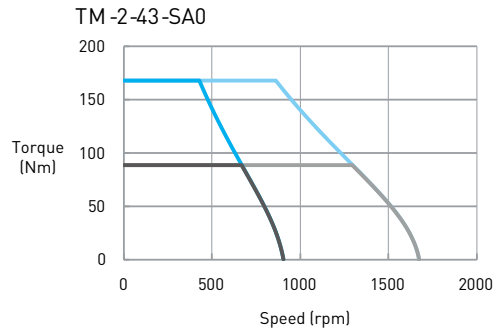
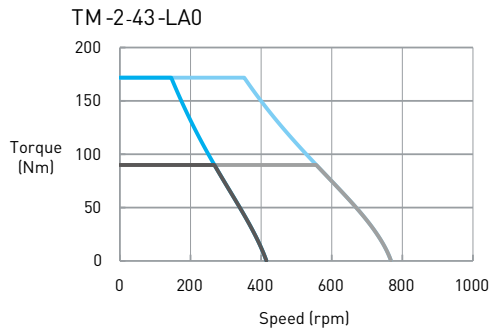

1.4 TM-2-7x

1.4.1 TM-2-7x Dimensions

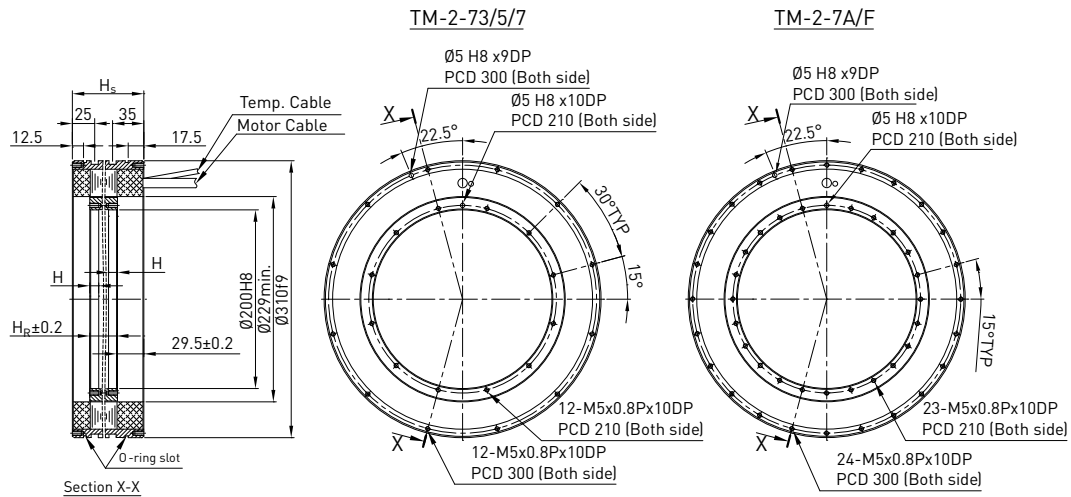

TM-2-7x Specifications

	Symbol	Unit	TM-2-73-LB0	TM-2-73-PB0	TM-2-75-PB0	TM-2-75-SB0	TM-2-77-PB0	TM-2-77-SB0	TM-2-7A-PB0	TM-2-7A-SB0	TM-2-7F-PB0	TM-2-7F-SB0
Continuous torque (WC)	T_{cw}	Nm	175	171	284	270	400	378	569	540	853	809
Continuous current (WC)	I_{cw}	A_{rms}	14	20.5	20.5	32.3	20.5	32.3	20.5	32.3	20.5	32.3
Stall torque (WC)	T_{sw}	Nm	144	141	233	222	329	310	468	442	701	663
Stall current (WC)	I_{sw}	A_{rms}	11.2	16.4	16.4	25.8	16.4	25.8	16.4	25.8	16.4	25.8
Peak torque (1s.)	T_p	Nm	345	340	570	545	800	760	1140	1110	1710	1670
Peak current (1s.)	I_p	A_{rms}	38.1	56	56	88.3	56	88.3	56	88.3	56	88.3
Torque constant	K_t	Nm/A_{rms}	13.34	8.83	14.9	8.83	20.78	12.47	29.62	17.84	44.51	26.67
Electrical time constant	T_e	ms	7.9	6.9	7	6.7	7	6.8	7	6.7	7	6.7
Resistance (line to line at 25°C)	R_{25}	Ω	3.5	1.7	2.5	1	3.3	1.3	4.5	1.8	6.5	2.6
Inductance (line to line)	L	mH	27.7	11.8	17.4	6.7	23	8.8	31.4	12	45.4	17.4
Number of poles	2p		44									
Back emf constant (line to line)	K_v	$V_{rms}/rad/s$	7.7	5.1	8.6	5.1	12	7.2	17.1	10.3	25.7	15.4
Motor constant (at 25°C)	K_m	Nm/\sqrt{W}	5.82	5.58	7.63	7.26	9.33	8.89	11.42	10.79	14.24	13.48
Thermal resistance (WC)	R_{thw}	K/W	0.092	0.089	0.06	0.061	0.046	0.047	0.033	0.034	0.023	0.023
Thermal sensor			PTC100+PTC130+Pt1000									
Max. DC BUS	V_{DC}		750									
Inertia of rotor	J	kgm^2	0.025	0.025	0.041	0.041	0.057	0.057	0.081	0.081	0.121	0.121
Max. speed at conti. Torque (WC)		rpm	319	506	307	532	217	380	147	261	90	167
Max. speed at Peak Torque		rpm	148	246	152	271	104	195	64	131	27	77
Rated speed ¹⁾	ω_n	rpm	319	409	307	409	217	380	147	261	90	167
Mass of rotor	M_r	kg	2.2	2.2	3.6	3.6	5	5	7.1	7.1	11.6	11.6
Mass of stator	M_s	kg	13.6	13.6	17.9	17.9	22.3	22.3	28.9	28.9	40.6	40.6
Height of stator	H_s	mm	80	80	100	100	120	120	150	150	200	200
Height of rotor	H_r	mm	31	31	51	51	71	71	101	101	151	151
Height	H	mm	10	10	15	15	15	15	15	15	15	15

Note : WC : water cooled

*All the specifications in the table are in $\pm 10\%$ of tolerance except dimensions.

¹⁾ The rated speed is the maximum speed which the motor can run continuously without rest.

More information please refer to Appendix B:Glossary.

1.5 TM-2-Ax

1.5.1 TM-2-Ax Dimensions

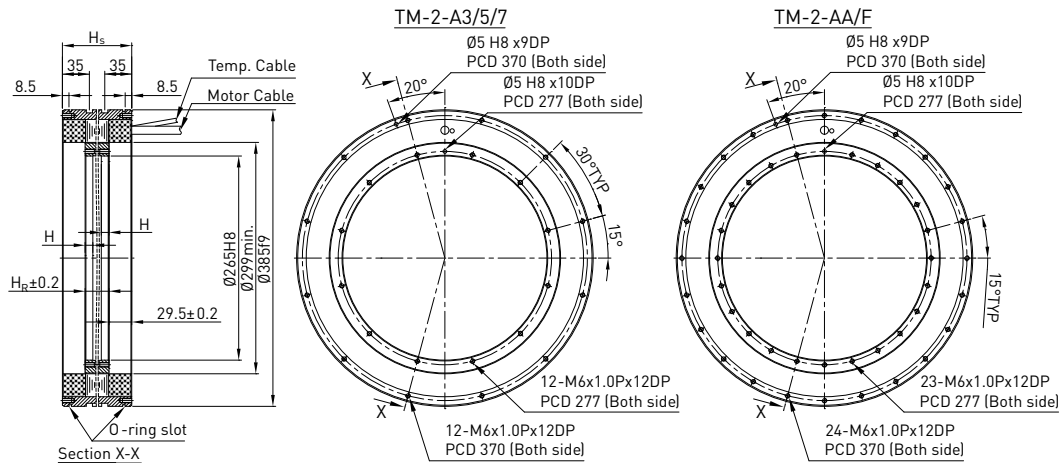

TM-2-Ax Specifications

	Symbol	Unit	TM-2-A3-PB0	TM-2-A3-PC0	TM-2-A5-PB0	TM-2-A5-PC0	TM-2-A7-PC0	TM-2-A7-PF0	TM-2-AA-PC0	TM-2-AA-PF0	TM-2-AF-PC0	TM-2-AF-PF0
Continuous torque (WC)	T_{cw}	Nm	272	272	453	453	633	633	905	905	1358	1358
Continuous current (WC)	I_{cw}	A_{rms}	23	35	23	35	35	70	35	70	35	70
Stall torque (WC)	T_{sw}	Nm	222	222	371	371	518	518	743	743	1114	1114
Stall current (WC)	I_{sw}	A_{rms}	18.4	28	18.4	28	28	56	28	56	28	56
Peak torque (1s.)	T_p	Nm	510	510	860	860	1200	1200	1720	1720	2580	2580
Peak current (1s.)	I_p	A_{rms}	52	78	52	78	78	156	78	156	78	156
Torque constant	K_t	Nm/A_{rms}	12.47	8.31	20.78	13.86	19.4	9.7	28.41	14.2	42.61	21.3
Electrical time constant	T_e	ms	6.9	6.7	6.8	6.8	6.8	6.8	6.7	6.7	6.8	6.8
Resistance (line to line at 25°C)	R_{25}	Ω	1.8	0.82	2.7	1.2	1.6	0.4	2.2	0.55	3.2	0.8
Inductance (line to line)	L	mH	12.4	5.5	18.3	8.2	10.8	2.7	14.8	3.7	21.6	5.4
Number of poles	2p		66									
Back emf constant (line to line)	K_v	$V_{rms}/rad/s$	7.2	4.8	12	8	11.2	5.6	16.4	8.2	24.6	12.3
Motor constant (at 25°C)	K_m	Nm/\sqrt{W}	7.46	7.36	10.31	10.31	12.53	12.53	15.6	15.6	19.44	19.44
Thermal resistance (WC)	R_{thw}	K/W	0.074	0.07	0.049	0.048	0.036	0.036	0.026	0.026	0.018	0.018
Thermal sensor			PTC100+PTC130+Pt1000									
Max. DC BUS	V_{DC}		750									
Inertia of rotor	J	kgm^2	0.065	0.065	0.108	0.108	0.151	0.151	0.214	0.214	0.32	0.32
Max. speed at conti. Torque (WC)		rpm	319	484	196	301	216	453	146	313	91	205
Max. speed at Peak. Torque		rpm	170	264	105	167	120	260	79	181	44	116
Rated speed ¹⁾	ω_n	rpm	272	272	196	272	216	272	146	272	91	205
Mass of rotor	M_r	kg	3.3	3.3	5.5	5.5	7.6	7.6	10.8	10.8	16.2	16.2
Mass of stator	M_s	kg	20.1	20.1	26.8	26.8	34.5	34.5	44.9	44.9	63.1	63.1
Height of stator	H_s	mm	90	90	110	110	130	130	160	160	210	210
Height of rotor	H_r	mm	31	31	51	51	71	71	101	101	151	151
Height	H	mm	10	10	15	15	15	15	15	15	15	15

Note : WC : water cooled

*All the specifications in the table are in $\pm 10\%$ of tolerance except dimensions.

¹⁾ The rated speed is the maximum speed which the motor can run continuously without rest.

More information please refer to Appendix B:Glossary.

1.5.2 TM-2-Ax Series T-N Curves

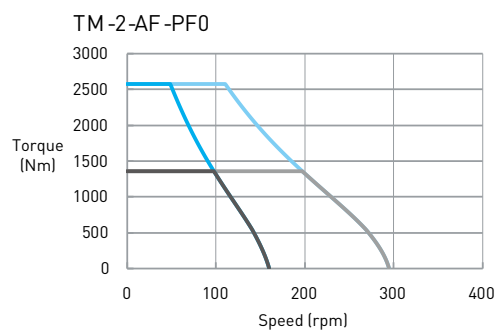
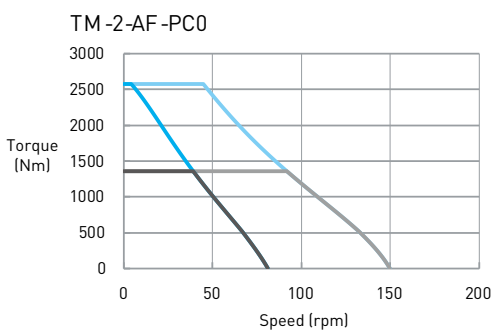
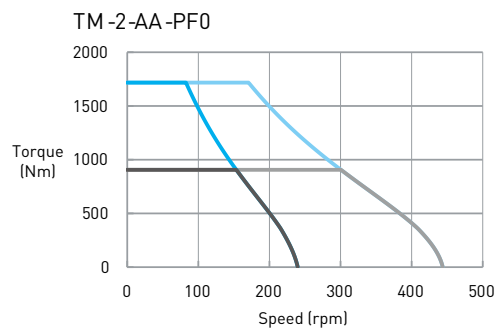
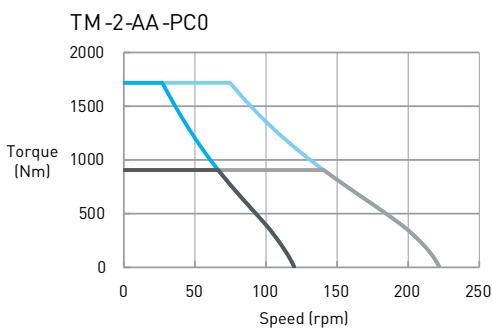
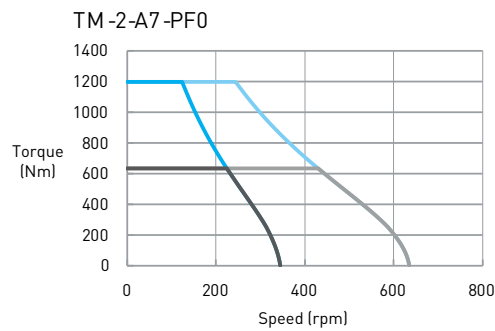
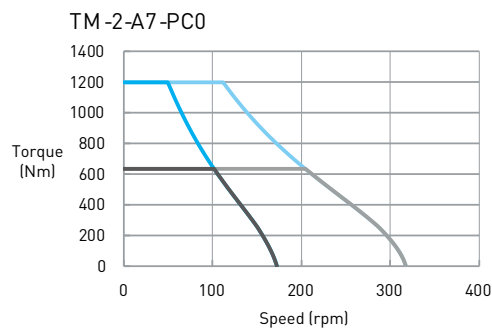
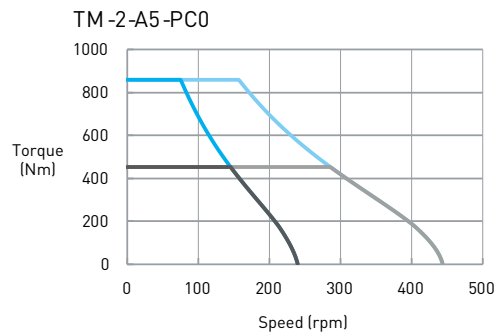
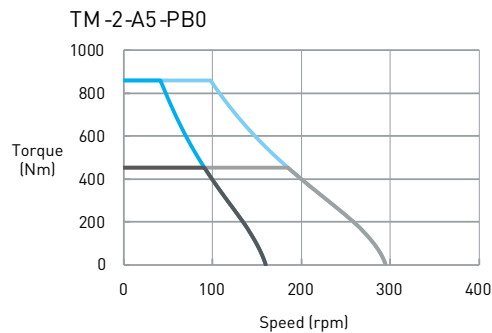
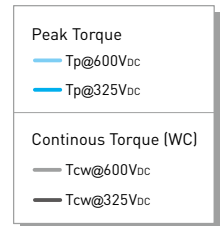
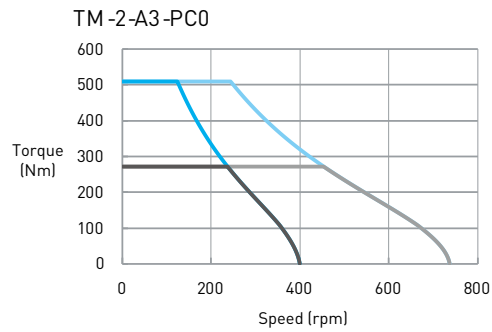
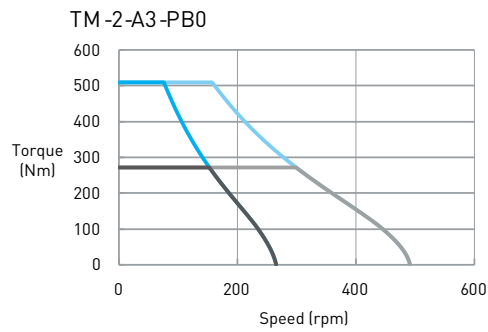

1.6 TM-2-Dx

1.6.1 TM-2-Dx Dimensions

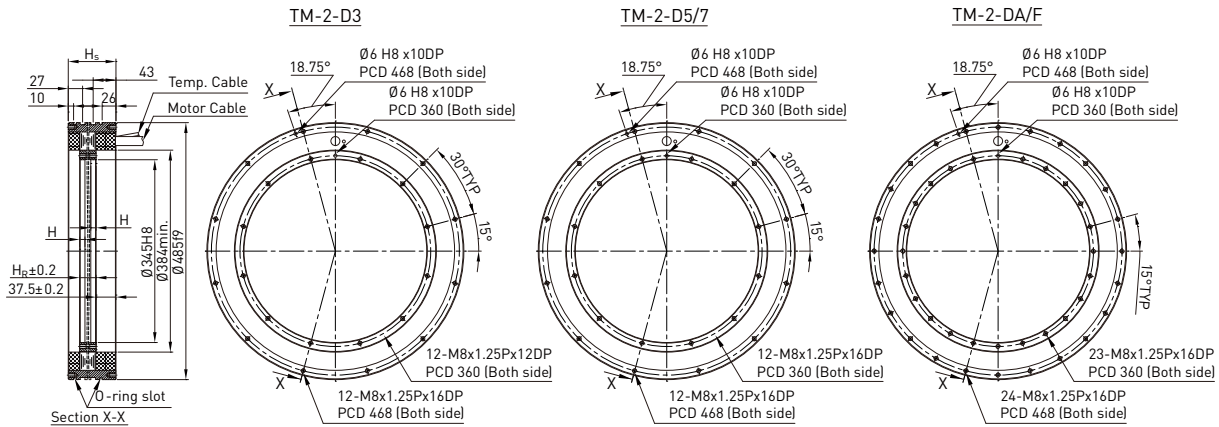

TM-2-Dx Specifications

	Symbol	Unit	TM-2-D3-SB0	TM-2-D3-SD0	TM-2-D5-SB0	TM-2-D5-SD0	TM-2-D7-SB0	TM-2-D7-SD0	TM-2-DA-SB0	TM-2-DA-SD0	TM-2-DF-SB0	TM-2-DF-SD0
Continuous torque (WC)	T _{cw}	Nm	415	415	700	700	990	990	1410	1410	2120	2120
Continuous current (WC)	I _{cw}	A _{rms}	35.4	70.8	35.4	70.8	35.4	70.8	35.4	70.8	35.4	70.8
Stall torque (WC)	T _{sw}	Nm	339	339	572	572	801	801	1146	1146	1719	1719
Stall current (WC)	I _{sw}	A _{rms}	28.3	56.6	28.3	56.6	28.3	56.6	28.3	56.6	28.3	56.6
Peak torque (1s.)	T _p	Nm	840	840	1410	1410	1980	1980	2820	2820	4240	4240
Peak current (1s.)	I _p	A _{rms}	106	212	106	212	106	212	106	212	106	212
Torque constant	K _t	Nm/A _{rms}	12.12	6.06	20.26	10.22	28.41	14.2	40.53	20.26	60.79	30.48
Electrical time constant	T _e	ms	6	6.3	6.3	6.1	6.2	6	6.2	6.2	6.1	6.1
Resistance (line to line at 25°C)	R ₂₅	Ω	1	0.24	1.4	0.36	1.9	0.48	2.6	0.65	3.8	0.95
Inductance (line to line)	L	mH	6	1.5	8.8	2.2	11.7	2.9	16	4	23.2	5.8
Number of poles	2p		88									
Back emf constant (line to line)	K _v	V _{rms} /rad/s	7	3.5	11.7	5.9	16.4	8.2	23.4	11.7	35.1	17.6
Motor constant (at 25°C)	K _m	Nm/√W	9.83	10.04	13.95	13.76	16.78	16.69	20.51	20.51	25.44	25.44
Thermal resistance (WC)	R _{thw}	K/W	0.056	0.058	0.04	0.039	0.029	0.029	0.021	0.021	0.015	0.015
Thermal sensor			PTC100+PTC130+Pt1000									
Max. DC BUS	V _{DC}		750									
Inertia of rotor	J	kgm ²	0.16	0.16	0.26	0.26	0.37	0.37	0.53	0.53	0.79	0.79
Max. speed at conti. Torque (WC)		rpm	327	672	204	423	145	308	98	214	60	139
Max. speed at Peak. Torque		rpm	134	282	84	184	57	135	35	93	12	57
Rated speed ¹⁾	ω _n	rpm	204	204	204	204	145	204	98	204	60	139
Mass of rotor	M _r	kg	4.8	4.8	7.9	7.9	11	11	15.8	15.8	23.6	23.6
Mass of stator	M _s	kg	20	20	35	35	50	50	73	73	105	105
Height of stator	H _s	mm	90	90	110	110	130	130	160	160	210	210
Height of rotor	H _r	mm	31	31	51	51	71	71	101	101	151	151
Height	H	mm	10	10	15	15	15	15	15	15	15	15

Note : WC : water cooled

*All the specifications in the table are in ±10% of tolerance except dimensions.

¹⁾ The rated speed is the maximum speed which the motor can run continuously without rest.

More information please refer to Appendix B:Glossary.

1.6.2 TM-2-Dx Series T-N Curves

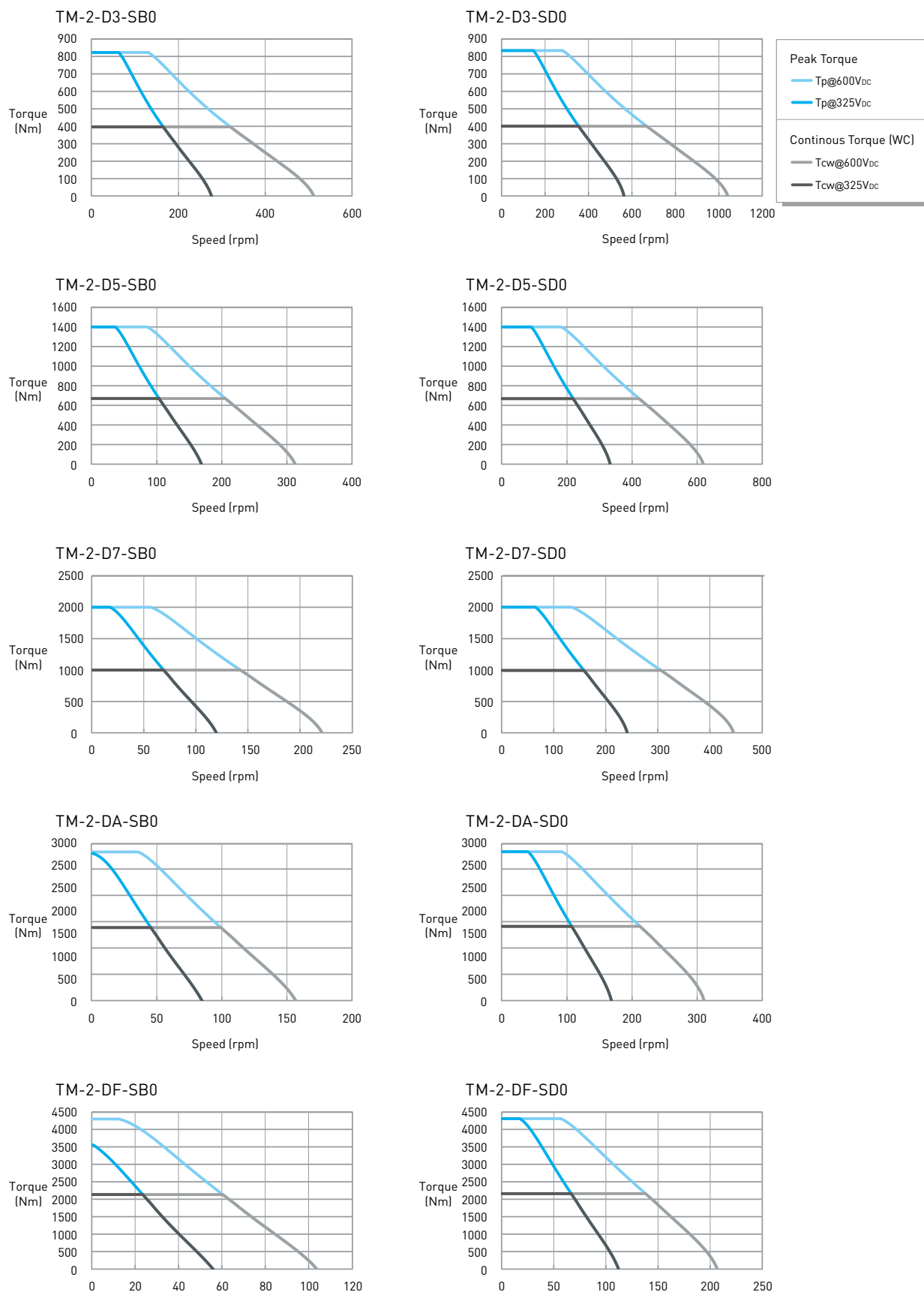

1.7 TM-2-Gx

1.7.1 TM-2-Gx Dimensions

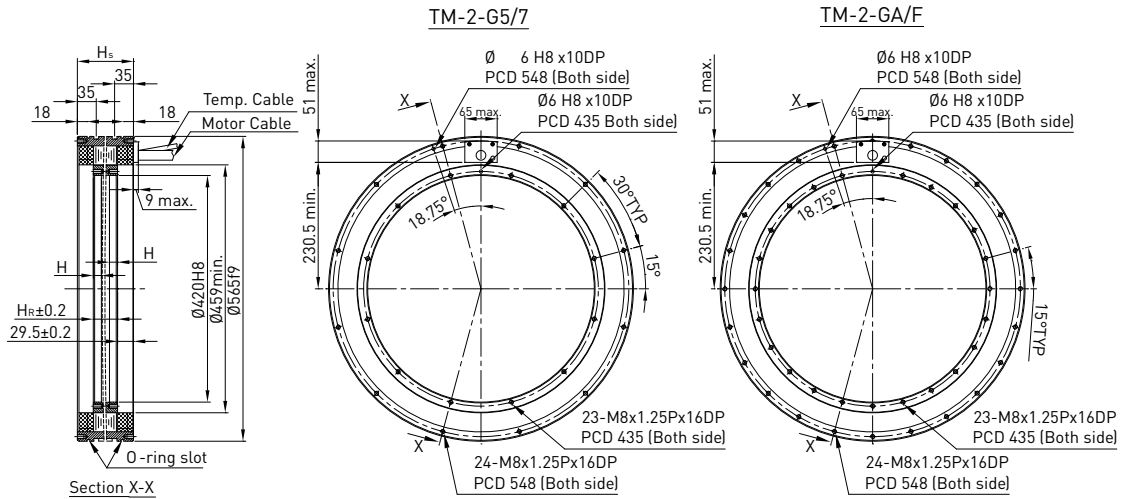

TM-2-Gx Specifications

	Symbol	Unit	TM-2-G5-SB0	TM-2-G5-SD0	TM-2-G7-SB0	TM-2-G7-SD0	TM-2-GA-SB0	TM-2-GA-SD0	TM-2-GF-SD0	TM-2-GF-SH0
Continuous torque (WC)	T_{cw}	Nm	1125	1125	1575	1575	2250	2250	3375	3375
Continuous current (WC)	I_{cw}	A_{rms}	30.3	60.6	30.3	60.6	30.3	60.6	60.6	121.2
Stall torque (WC)	T_{sw}	Nm	930	931	1302	1304	1860	1863	2794	2794
Stall current (WC)	I_{sw}	A_{rms}	24.2	48.5	24.2	48.5	24.2	48.5	48.5	97
Peak torque (1s.)	T_p	Nm	2000	2000	2800	2800	4000	4000	6000	6000
Peak current (1s.)	I_p	A_{rms}	80	160	80	160	80	160	160	320
Torque constant	K_t	Nm/ A_{rms}	40.18	20.09	56.29	28.06	80.37	40.18	60.28	30.14
Electrical time constant	T_e	ms	10	10.2	10.1	10	10.1	10.1	10.1	10.1
Resistance (line to line at 25°C)	R_{25}	Ω	2.1	0.52	2.76	0.7	3.76	0.94	1.36	0.34
Inductance (line to line)	L	mH	21	5.3	27.8	7	38	9.5	13.7	3.43
Number of poles	$2p$		88							
Back emf constant (line to line)	K_v	Vrms/rad/s	23.2	11.6	32.5	16.2	46.4	23.2	34.8	17.4
Motor constant (at 25°C)	K_m	Nm/ \sqrt{W}	22.59	22.7	27.65	27.45	33.81	33.81	42.08	42.08
Thermal resistance (WC)	R_{thw}	K/W	0.036	0.037	0.028	0.027	0.02	0.02	0.014	0.014
Thermal sensor			PTC100+PTC130+Pt1000							
Max. DC BUS		V_{DC}	750							
Inertia of rotor	J	kgm ²	0.452	0.452	0.619	0.619	0.904	0.904	1.38	1.38
Max. speed at conti. Torque (WC)]		rpm	99	208	70	150	47	105	68	146
Max. speed at Peak. Torque		rpm	44	99	30	72	17	49	30	72
Rated speed ¹⁾	ω_n	rpm	99	204	70	150	47	105	68	146
Mass of rotor	M_r	kg	9.7	9.7	13.5	13.5	19.3	19.3	29	29
Mass of stator	M_s	kg	50	50	63.5	63.5	78	78	111.8	111.8
Height of stator	H_s	mm	110	110	130	130	160	160	210	210
Height of rotor	H_R	mm	51	51	71	71	101	101	151	151
Height	H	mm	15	15	15	15	15	15	15	15

Note : WC : water cooled

*All the specifications in the table are in $\pm 10\%$ of tolerance except dimensions.

¹⁾ The rated speed is the maximum speed which the motor can run continuously without rest.

More information please refer to Appendix B:Glossary.

1.7.2 TM-2-Gx Series T-N Curves

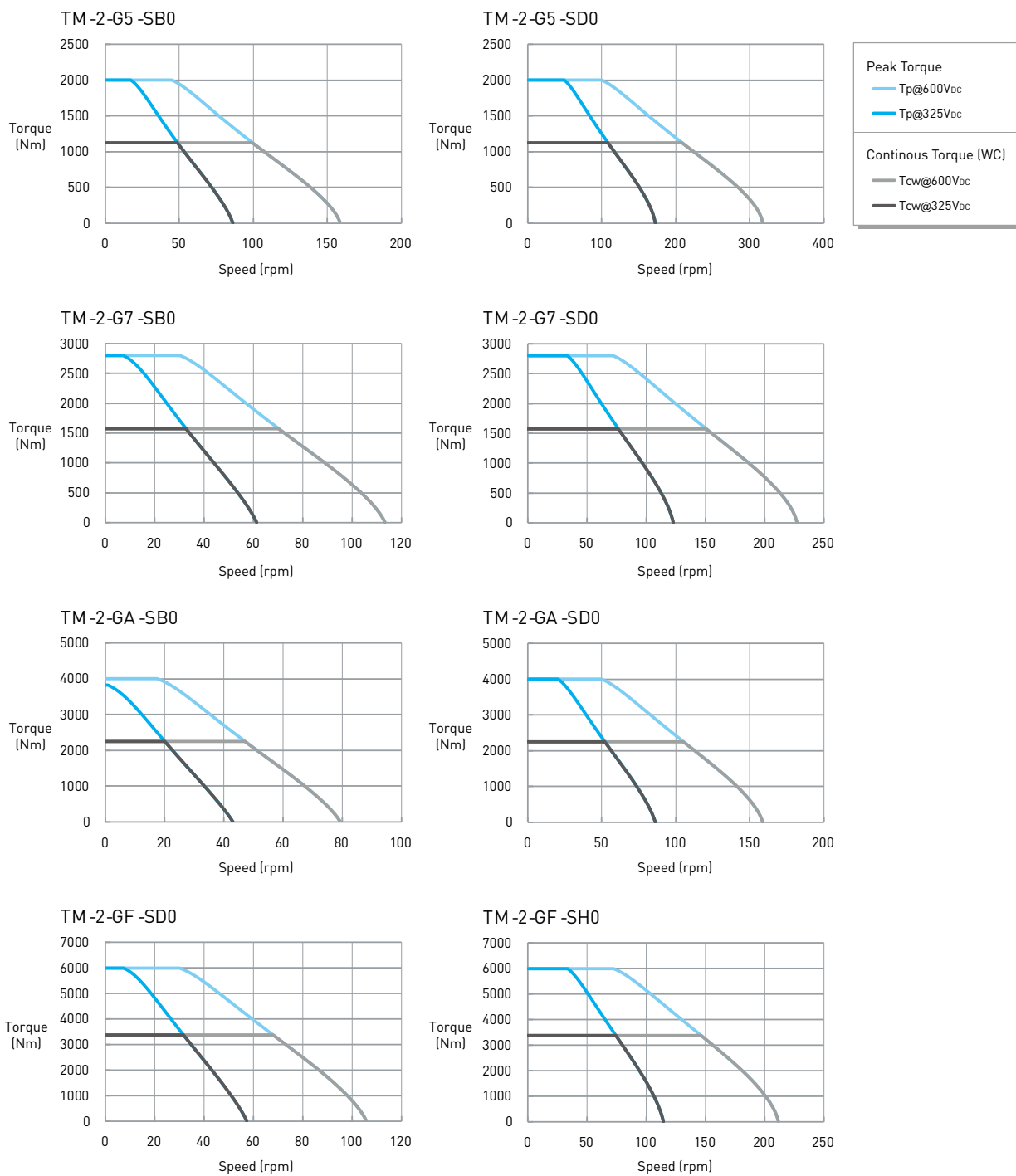

2. IM-2 Motor

Since its special rotor design can provide higher speed under field weakening control, IM-2 Series can be more suitable for turning and milling combined processing. With the same size and the same installation interface, when the liquid cooling system is used to dissipate heat, IM-2 series has better performance. Besides, IM-2 series has larger continuous torque and lowers the operating temperature of motor. To avoid the motor from accumulating too much energy during operation, all IM-2 torque motors are equipped with temperature sensors. Even if the motor carries extreme load, it will be protected from damage.

Key features of the IM-2 torque motor:

- Optimized for high speed ranges
- High continuous and peak torque
- High dynamics, high efficiency
- Wear-free operation, maintenance-free
- Built-in temperature sensor

Typical fields of application:

- Machine tools
- Turning and milling centers

■ Model Numbers for IM-2 Series

Motor Specification	Temp. Sensor	Cable Output	Reserved Code
IM - 2 - 1 3 - P A 0	- 0 -	20 V -	0 0
<p>Series: IM-2: IM Motor</p> <p>External Diameter of Stator: 2: Ø198mm 4: Ø230mm 7: Ø310mm A: Ø385mm G: Ø565mm</p> <p>Rotor (Magnet) Height: 3: 30mm 5: 50mm 7: 70mm A: 100mm F: 150mm</p> <p>Torque / Speed Characteristics Code: See motor datasheet</p> <p>Temperature sensor configuration : 0: PTC100+PTC130+Pt1000 (Standard) 1: PTC100+PTC130+Pt1000x3</p> <p>Cable Length: 20: 2.0m (Standard) 05: 0.5m 10: 1.0m</p> <p>Cable Output Style: S: Straight output V: Straight output with cable clamp A: Straight output with cable gland H: 90° output in tangent direction with cable clamp (temp. cable straight output) P: All cable separate with cable clamp (straight output)</p> <p>Reserved: 00: Standard(without bridge) 03: Bridge on cable side</p>			

2.1 IM-2-2x

2.1.1 IM-2-2x Dimensions

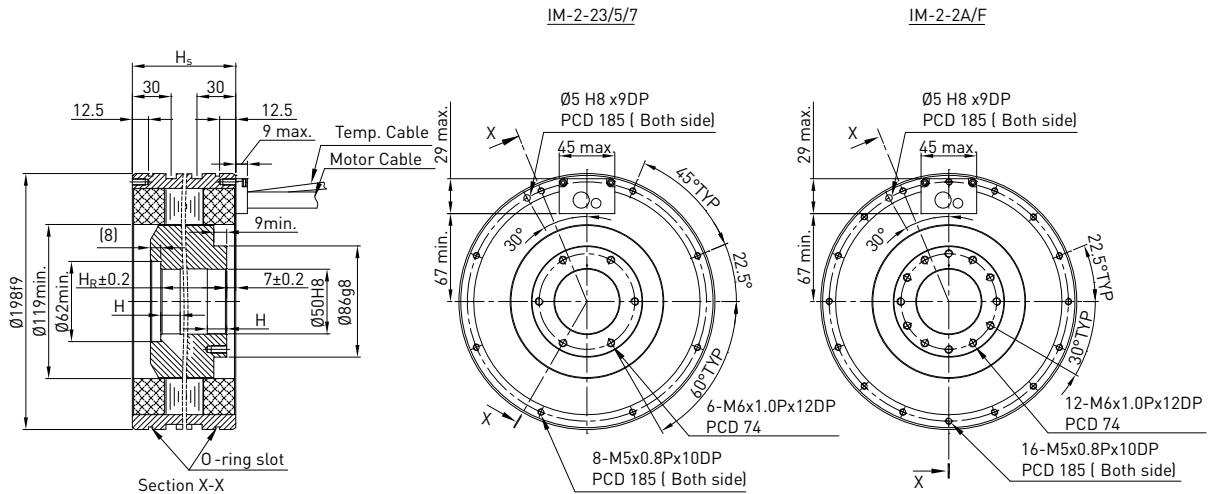

IM-2-2x Specifications

	Symbol	Unit	IM-2-23-PA0	IM-2-23-PB0	IM-2-25-PA0	IM-2-25-PB0	IM-2-27-PA0	IM-2-27-PB0	IM-2-2A-PB0	IM-2-2A-PD0	IM-2-2F-PB0	IM-2-2F-PD0
Continuous torque (WC)	T_{cw}	Nm	49.8	49.8	83	83	116.2	116.2	168	168	250	250
Continuous current (WC)	I_{cw}	A_{rms}	10.2	20.4	10.2	20.4	10.2	20.4	20.4	40.8	20.4	40.8
Stall torque (WC)	T_{sw}	Nm	42	42	70	70	98	98	141	141	210	210
Stall current (WC)	I_{sw}	A_{rms}	8.2	16.3	8.2	16.3	8.2	16.3	16.3	32.6	16.3	32.6
Peak torque (1s.)	T_p	Nm	76	76	128	128	179	179	256	256	384	384
Peak current (1s.)	I_p	A_{rms}	25.5	51	25.5	51	25.5	51	51	102	51	102
Torque constant	K_t	Nm/A_{rms}	5.54	2.77	9.35	4.68	13.16	6.58	9.35	4.68	14.03	7.1
Electrical time constant	T_e	ms	7.3	7.1	7.2	7.2	7.2	7.3	7.1	7.2	7.2	7.3
Resistance (Line to line at 25°C)	R_{25}	Ω	3.5	0.9	5.2	1.3	6.9	1.7	2.4	0.6	3.4	0.85
Inductance (line to line)	L	mH	25.5	6.4	37.6	9.4	49.7	12.4	17	4.3	24.6	6.2
Number of poles	$2p$		22									
Back emf constant (line to line)	K_v	$V_{rms}/(rad/s)$	3.2	1.6	5.4	2.7	7.6	3.8	5.4	2.7	8.1	4.1
Motor constant (at 25°C)	K_m	Nm/\sqrt{W}	2.41	2.38	3.35	3.35	4.09	4.12	4.92	4.92	6.21	6.21
Thermal resistance (WC)	R_{thw}	K/W	0.192	0.187	0.129	0.129	0.098	0.099	0.07	0.07	0.049	0.049
Thermal Sensor			PTC100+PTC130+Pt1000									
Max. DC BUS		V_{DC}	750									
Inertia of rotor	J	kgm^2	0.0051	0.0051	0.0079	0.0079	0.0107	0.0107	0.0146	0.0146	0.0215	0.0215
Max. speed [Conti. torque]		rpm	856	1763	513	1078	358	769	531	1110	342	726
Max. speed (Field Weakening)		rpm	5000	5450	3200	5450	2300	4600	3200	5450	2150	4100
Mass of rotor	M_r	kg	2.74	2.74	4.09	4.09	5.43	5.43	7.43	7.43	10.79	10.79
Mass of stator	M_s	kg	6.5	6.5	9	9	11.2	11.2	15	15	22.2	22.2
Height of stator	H_s	mm	80	80	100	100	120	120	150	150	200	200
Height of rotor	H_r	mm	51	51	71	71	91	91	121	121	171	171
Length of rotor centering fit	H	mm	15	15	20	20	20	20	20	20	20	20

Note : WC : water cooled

*All the specifications in the table are in $\pm 10\%$ of tolerance except dimensions.

2.1.2 IM-2-2x Series T-N Curves

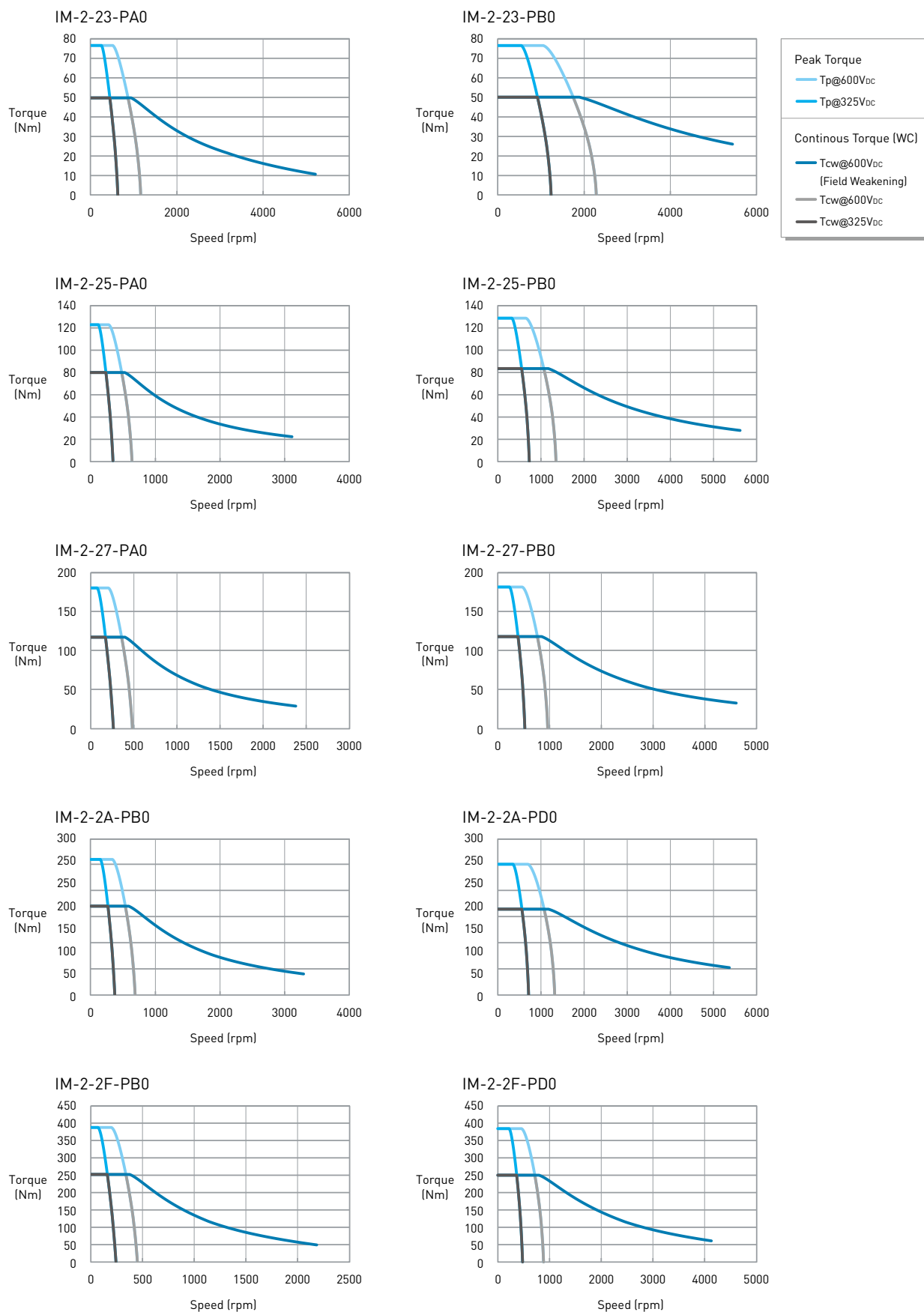

2.2 IM-2-4x

2.2.1 IM-2-4x Dimensions

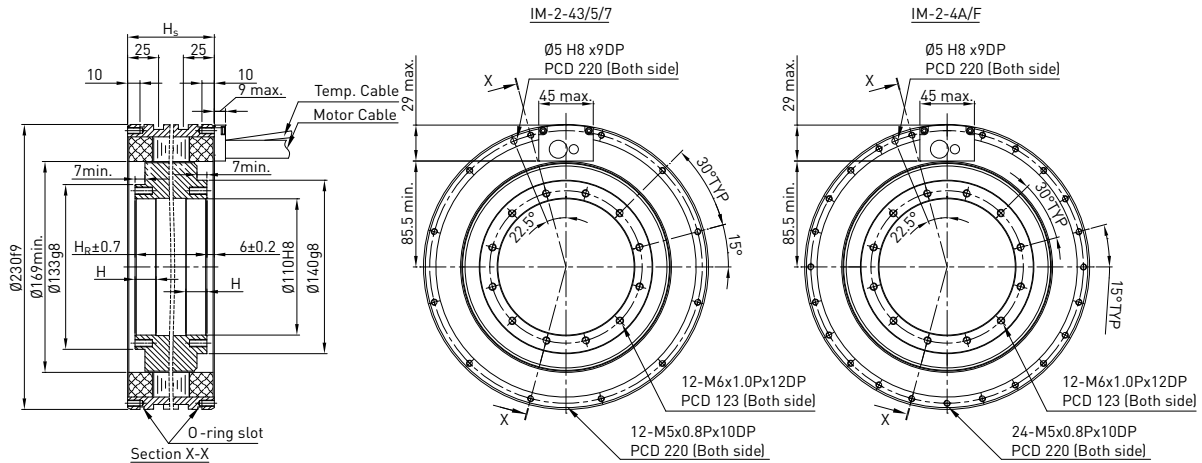

IM-2-4x Specifications

	Symbol	Unit	IM-2-43-LA0	IM-2-43-SA0	IM-2-45-LA0	IM-2-45-SA0	IM-2-47-SA0	IM-2-47-SB0	IM-2-4A-SA0	IM-2-4A-SB0	IM-2-4F-SA0	IM-2-4F-SB0
Continuous torque (WC)	T_{cw}	Nm	90	89	151	148	207	207	295	295	443	443
Continuous current (WC)	I_{cw}	A_{rms}	11.4	24.9	11.4	24.9	24.9	49.8	24.9	49.8	24.9	49.8
Stall torque (WC)	T_{sw}	Nm	73	72	122	120	168	168	239	239	336	336
Stall current (WC)	I_{sw}	A_{rms}	9.1	19.9	9.1	19.9	19.9	39.8	19.9	39.8	19.9	39.8
Peak torque (1s.)	T_p	Nm	172	168	286	281	393	393	561	561	842	842
Peak current (1s.)	I_p	A_{rms}	23.7	52	23.7	52	52	104	52	104	52	104
Torque constant	K_t	Nm/A_{rms}	8.31	3.81	13.86	6.41	8.66	4.33	12.47	6.24	18.53	9.35
Electrical time constant	T_e	ms	3	2.9	2.9	3	3	2.8	3	2.9	3	3.1
Resistance (Line to line at 25°C)	R_{25}	Ω	5.6	1.2	8.3	1.72	2.3	0.6	3.1	0.8	4.5	1.1
Inductance (line to line)	L	mH	16.8	3.5	23.8	5.1	6.8	1.7	9.3	2.3	13.4	3.4
Number of poles	$2p$		40									
Back emf constant (line to line)	K_v	$V_{rms}/rad/s$	4.8	2.2	8	3.7	5	2.5	7.2	3.6	10.7	5.4
Motor constant (at 25°C)	K_m	Nm/\sqrt{W}	2.86	2.84	3.89	3.93	4.6	4.51	5.74	5.65	7.09	7.17
Thermal resistance (WC)	R_{thw}	K/W	0.096	0.094	0.065	0.066	0.049	0.047	0.036	0.035	0.025	0.026
Thermal Sensor			PTC100+PTC130+Pt1000									
Max. DC BUS		V_{DC}	750									
Inertia of rotor	J	kgm^2	0.018	0.018	0.027	0.027	0.036	0.036	0.049	0.049	0.071	0.071
Max. speed (Conti. torque)		rpm	561	1310	328	790	570	1203	384	831	240	539
Max. speed [Field Weakening]	$\omega_{max,field}$	rpm	1500	3000	1000	3000	1500	3000	1500	3000	1000	2500
Mass of rotor	M_r	kg	3.7	3.7	5.4	5.4	7.2	7.2	9.6	9.6	13.9	13.9
Mass of stator	M_s	kg	6.5	6.5	9	9	11.2	11.2	15	15	22.2	22.2
Height of stator	H_s	mm	70	70	90	90	110	110	140	140	190	190
Height of rotor	H_r	mm	58	58	78	78	98	98	128	128	178	178
Height	H	mm	17	17	17	17	17	17	17	17	17	17

Note : WC : water cooled

*All the specifications in the table are in $\pm 10\%$ of tolerance except dimensions.

2.2.2 IM-2-4x Series T-N Curves

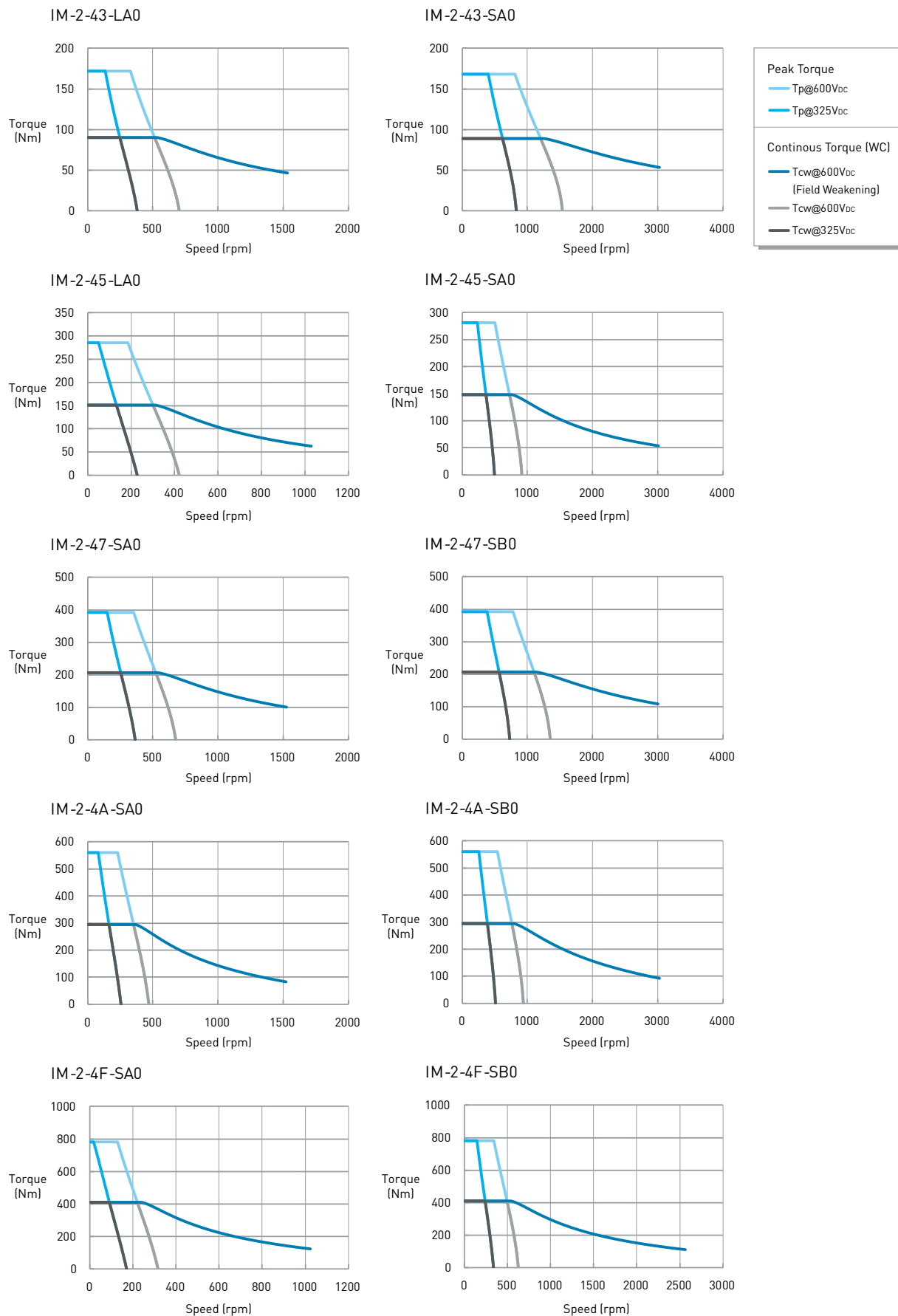

2.3 IM-2-7x

2.3.1 IM-2-7x Dimensions

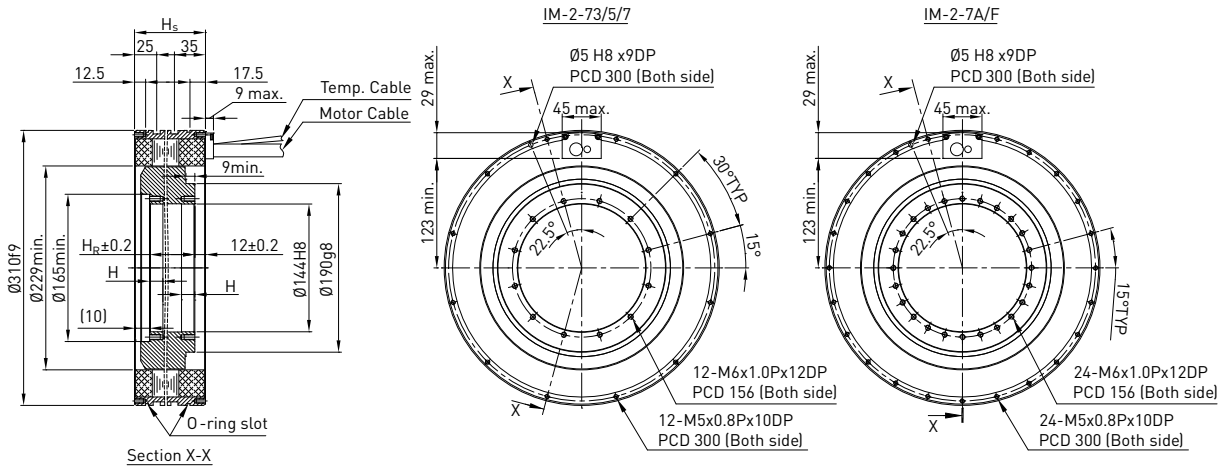

IM-2-7x Specifications

	Symbol	Unit	IM-2-73-SA0	IM-2-73-SB0	IM-2-75-SB0	IM-2-75-SD0	IM-2-77-SB0	IM-2-77-SD0	IM-2-7A-SB0	IM-2-7A-SD0	IM-2-7F-SD0	IM-2-7F-WD0
Continuous torque (WC)	T_{cw}	Nm	167	167	279	279	390	390	557	557	836	797
Continuous current (WC)	I_{cw}	A_{rms}	16.2	32.3	32.3	64.5	32.3	64.5	32.3	64.5	64.5	125.7
Stall torque (WC)	T_{sw}	Nm	138	137	229	229	321	321	458	458	688	656
Stall current (WC)	I_{sw}	A_{rms}	13	25.8	25.8	51.6	25.8	51.6	25.8	51.6	51.6	100.6
Peak torque (1s.)	T_p	Nm	298	298	495	495	690	690	990	990	1485	1415
Peak current (1s.)	I_p	A_{rms}	44.2	88.3	88.3	176.6	88.3	176.6	88.3	176.6	176.6	344
Torque constant	K_t	Nm/A_{rms}	11.29	5.65	9.41	4.69	13.16	6.58	18.88	9.35	14.03	6.86
Electrical time constant	T_e	ms	6.7	6.6	6.7	6.6	6.7	6.7	6.7	6.7	6.6	6.6
Resistance (Line to line at 25°C)	R_{25}	Ω	2.7	0.68	1	0.25	1.32	0.33	1.8	0.45	0.65	0.17
Inductance (line to line)	L	mH	18.1	4.52	6.65	1.66	8.8	2.2	12	3	4.3	1.13
Number of poles	2p		44									
Back emf constant (line to line)	K_v	$V_{rms}/rad/s$	6.52	3.26	5.43	2.71	7.6	3.8	10.9	5.4	8.1	3.96
Motor constant (at 25°C)	K_m	Nm/\sqrt{W}	5.28	5.31	7.25	7.25	8.87	8.87	10.86	10.86	13.53	12.97
Thermal resistance (WC)	R_{thw}	K/W	0.099	0.099	0.067	0.067	0.051	0.051	0.037	0.037	0.026	0.026
Thermal Sensor			PTC100+PTC130+Pt1000									
Max. DC BUS	V_{DC}		750									
Inertia of rotor	J	kgm^2	0.071	0.071	0.104	0.104	0.138	0.138	0.187	0.187	0.271	0.271
Max. speed (Conti. torque)		rpm	399	829	512	1057	366	761	251	535	353	740
Max. speed (Field Weakening)	$\omega_{max,field}$	rpm	1500	2730	2500	2730	1700	2730	1250	2400	1700	2730
Mass of rotor	M_r	kg	8.2	8.2	11.8	11.8	15.5	15.5	21	21	30.2	30.2
Mass of stator	M_s	kg	13.6	13.6	17.9	17.9	22.3	22.3	28.9	28.9	40.6	40.6
Height of stator	H_s	mm	80	80	100	100	120	120	150	150	200	200
Height of rotor	H_r	mm	51	51	71	71	91	91	121	121	171	171
Height	H	mm	15	15	20	20	20	20	20	20	20	20

Note : WC : water cooled

*All the specifications in the table are in $\pm 10\%$ of tolerance except dimensions.

2.3.2 IM-2-7x Series T-N Curves

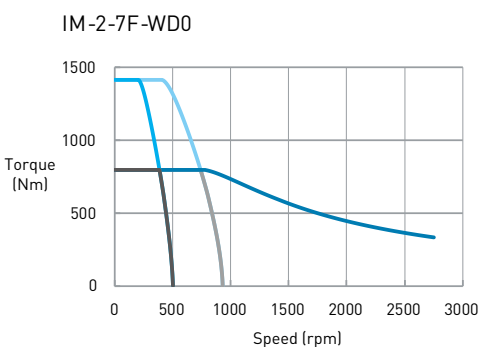
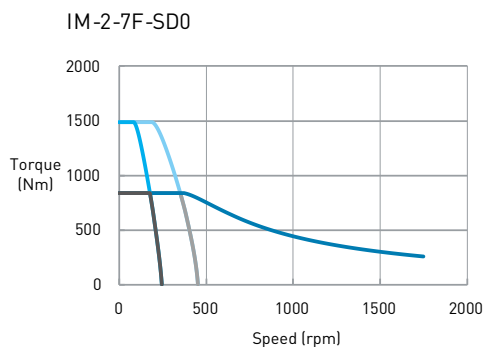
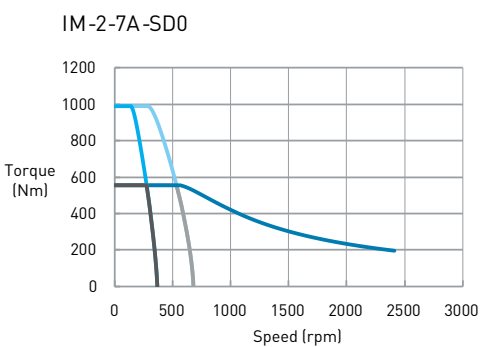
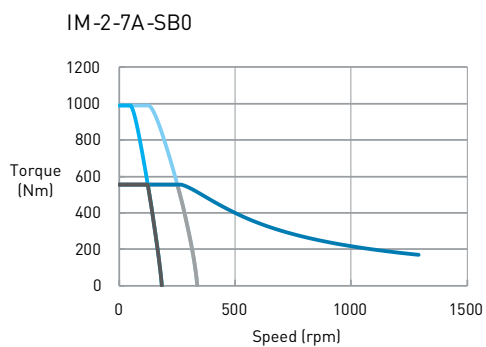
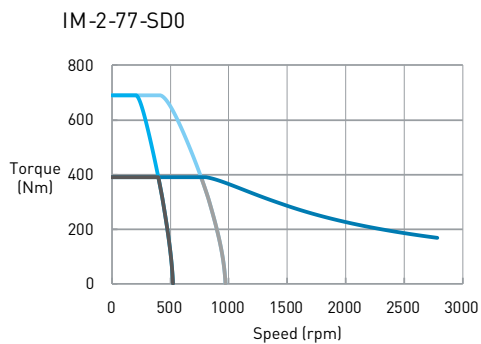
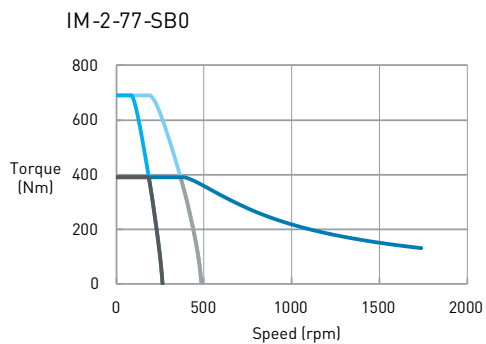
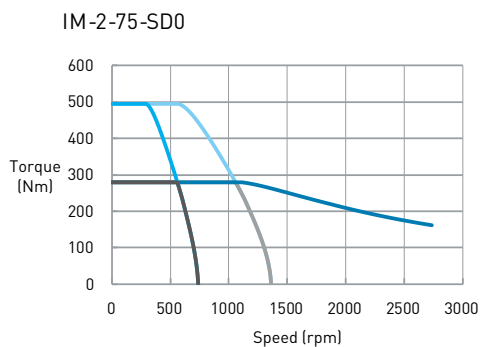
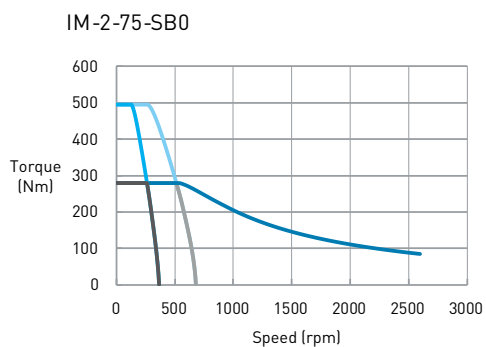
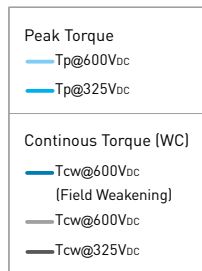
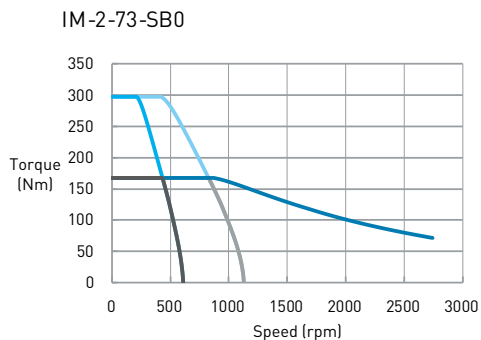
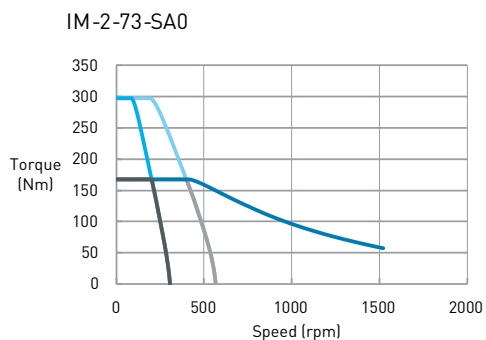

2.4 IM-2-Ax

2.4.1 IM-2-Ax Dimensions

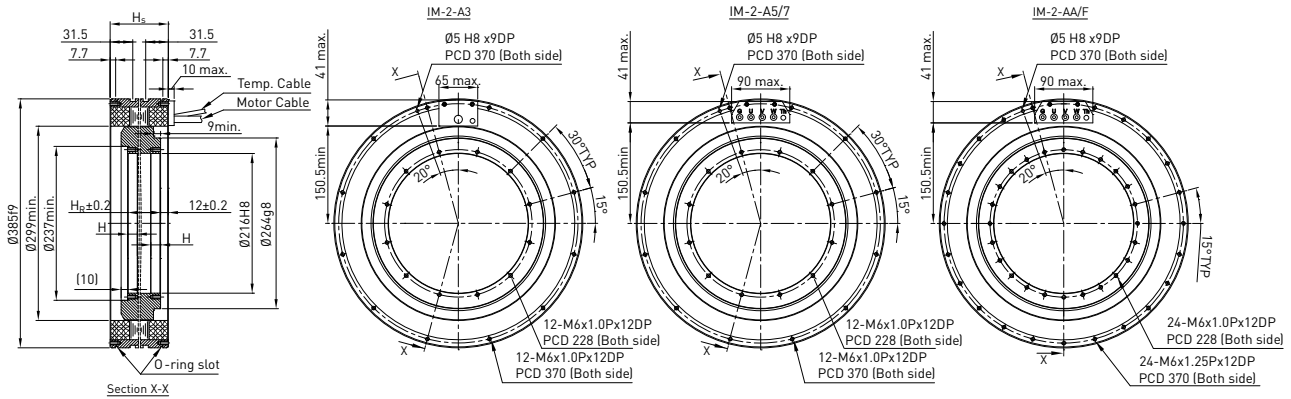

IM-2-Ax Specifications

	Symbol	Unit	IM-2-A3-PB0	IM-2-A3-PC0	IM-2-A5-PC0	IM-2-A5-PF0	IM-2-A7-PC0	IM-2-A7-PF0	IM-2-AA-PC0	IM-2-AA-PF0	IM-2-AF-PF0	IM-2-AF-SF0
Continuous torque (WC)	T_{cw}	Nm	320	320	540	540	756	756	1080	1080	1620	1480
Continuous current (WC)	I_{cw}	A_{rms}	23	35	35	70	35	70	35	70	70	114.4
Stall torque (WC)	T_{sw}	Nm	268	268	453	453	634	634	907	907	1361	1242
Stall current (WC)	I_{sw}	A_{rms}	18.4	28	28	56	28	56	28	56	56	91.5
Peak torque (1s.)	T_p	Nm	490	490	810	810	1140	1140	1630	1630	2440	2230
Peak current (1s.)	I_p	A_{rms}	52	78	78	156	78	156	78	156	156	255
Torque constant	K_t	Nm/ A_{rms}	15.59	10.39	17.32	8.66	24.25	12.12	35.33	17.67	26.5	14.72
Electrical time constant	T_e	ms	6.9	6.7	6.8	6.7	6.8	6.8	6.7	6.7	6.8	6.7
Resistance (Line to line at 25°C)	R_{25}	Ω	1.8	0.82	1.2	0.3	1.6	0.4	2.2	0.55	0.8	0.3
Inductance (line to line)	L	mH	12.4	5.5	8.2	2	10.8	2.7	14.8	3.7	5.4	2
Number of poles	$2p$		66									
Back emf constant (line to line)	K_v	Vrms/rad/s	9	6	10	5	14	7	20.4	10.2	15.3	8.5
Motor constant (at 25°C)	K_m	Nm/ \sqrt{W}	9.43	9.32	12.86	12.86	15.65	15.65	19.4	19.4	24.19	21.94
Thermal resistance (WC)	R_{thw}	K/W	0.074	0.07	0.048	0.048	0.036	0.036	0.026	0.026	0.018	0.018
Thermal Sensor			PTC100+PTC130+Pt1000									
Max. DC BUS		V_{DC}	750									
Inertia of rotor	J	kgm ²	0.185	0.185	0.27	0.27	0.355	0.355	0.482	0.482	0.694	0.694
Max. speed (Conti. torque)		rpm	283	432	265	555	188	397	126	273	177	324
Max. speed (Field Weakening)	$\omega_{max,field}$	rpm	1200	1700	1600	1850	1200	1850	800	1600	1050	1600
Mass of rotor	M_r	kg	11.3	11.3	16.3	16.3	21.3	21.3	28.7	28.7	41.2	41.2
Mass of stator	M_s	kg	20.1	20.1	26.8	26.8	34.5	34.5	44.9	44.9	63.1	63.1
Height of stator	H_s	mm	90	90	110	110	130	130	160	160	210	210
Height of rotor	H_R	mm	51	51	71	71	91	91	121	121	171	171
Height	H	mm	15	15	20	20	20	20	20	20	20	20

Note : WC : water cooled

*All the specifications in the table are in $\pm 10\%$ of tolerance except dimensions.

2.4.2 IM-2-Ax Series T-N Curves

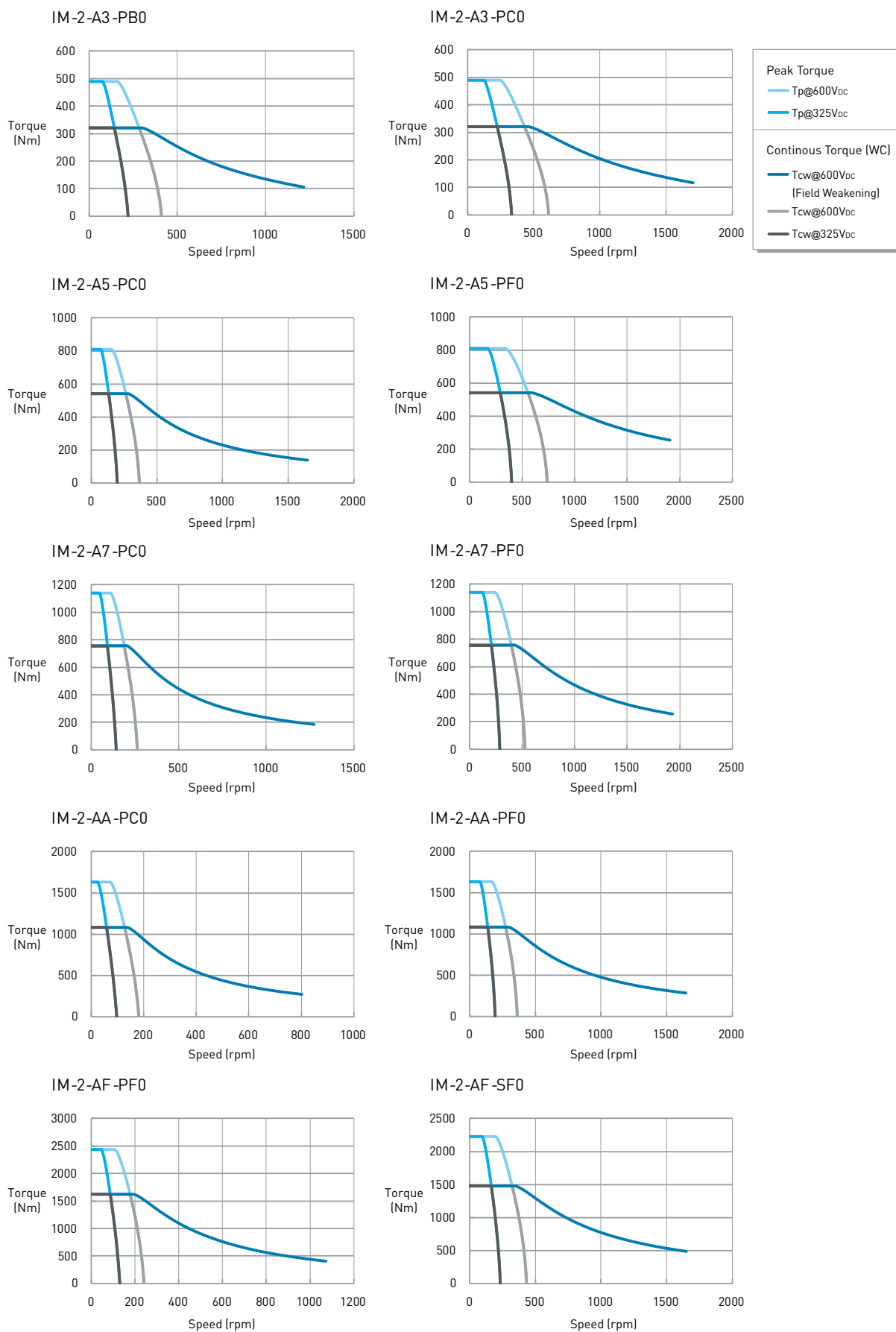

2.5 IM-2-Gx

2.5.1 IM-2-Gx Dimensions

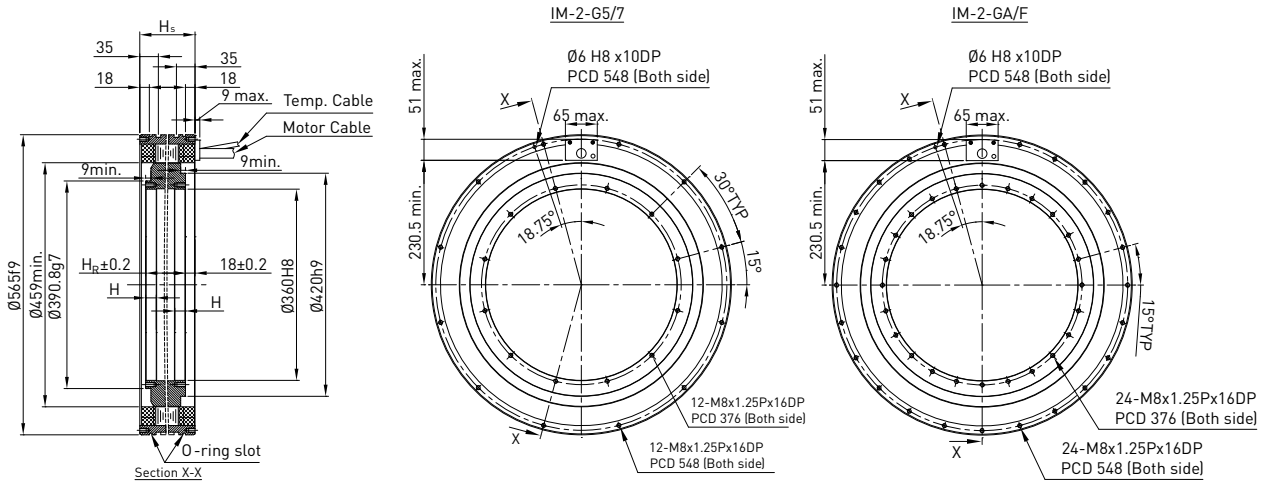

IM-2-Gx Specifications

	Symbol	Unit	IM-2-G5-SB0	IM-2-G5-SD0	IM-2-G7-SB0	IM-2-G7-SD0	IM-2-GA-SB0	IM-2-GA-SD0	IM-2-GF-SD0	IM-2-GF-SH0
Continuous torque (WC)	T_{cw}	Nm	1080	1080	1510	1510	2160	2160	3240	3240
Continuous current (WC)	I_{cw}	A_{rms}	30.3	60.6	30.3	60.6	30.3	60.6	60.6	121.2
Stall torque (WC)	T_{sw}	Nm	890	892	1245	1247	1781	1784	2676	2676
Stall current (WC)	I_{sw}	A_{rms}	24.2	48.5	24.2	48.5	24.2	48.5	48.5	97
Peak torque (1s.)	T_p	Nm	1900	1900	2660	2660	3800	3800	5700	5700
Peak current (1s.)	I_p	A_{rms}	80	160	80	160	80	160	160	320
Torque constant	K_t	Nm/A_{rms}	38.45	19.23	53.87	27.02	76.9	38.45	57.68	28.93
Electrical time constant	T_e	ms	10	10	10.1	10	10.1	10.1	9.9	8.8
Resistance (Line to line at 25°C)	R_{25}	Ω	2.1	0.53	2.75	0.7	3.76	0.94	1.4	0.4
Inductance (line to line)	L	mH	21	5.3	27.8	7	38	9.5	13.8	3.5
Number of poles	2p		88							
Back emf constant (line to line)	K_v	$V_{rms}/rad/s$	22.2	11.1	31.1	15.6	44.4	22.2	33.3	16.7
Motor constant (at 25°C)	K_m	Nm/\sqrt{W}	21.13	21.03	25.85	25.62	31.58	31.58	38.82	36.31
Thermal resistance (WC)	R_{thw}	K/W	0.036	0.036	0.028	0.027	0.02	0.02	0.014	0.012
Thermal Sensor			PTC100+PTC130+Pt1000							
Max. DC BUS		V_{DC}	750							
Inertia of rotor	J	kgm^2	1.14	1.14	1.6	1.6	2.28	2.28	3.42	3.42
Max. speed (Conti. torque)		rpm	101	215	72	155	48	108	70	146
Max. speed (Field Weakening)	$\omega_{max,field}$	rpm	600	1200	400	800	300	600	200	400
Mass of rotor	M_r	kg	27.1	27.1	38.1	38.1	54.3	54.3	81.5	81.5
Mass of stator	M_s	kg	50	50	63.5	63.5	78	78	111.8	111.8
Height of stator	H_s	mm	110	110	130	130	160	160	210	210
Height of rotor	H_r	mm	81	81	101	101	131	131	181	181
Height	H	mm	20	20	20	20	20	20	20	20

Note : WC : water cooled

*All the specifications in the table are in $\pm 10\%$ of tolerance except dimensions.

2.5.2 IM-2-Gx Series T-N Curves

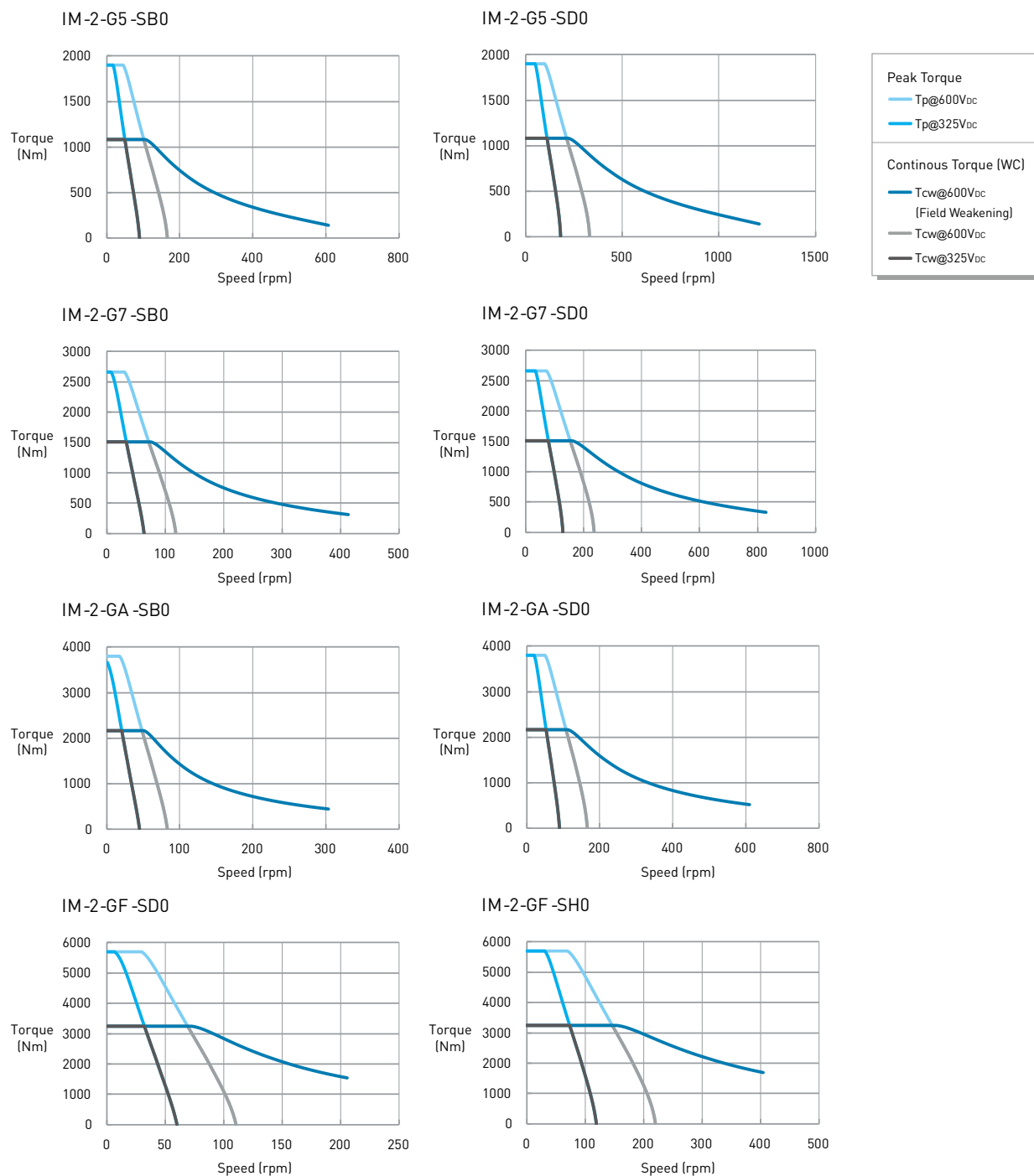

Appendix A: Torque Motor Selection

The way to select a suitable motor based on speed, moving distance, and loading inertia is described in the following contents. The basic process for sizing a motor is as below:

Requirement
○ Operating environment
○ Installation (horizontal or vertical)
○ Driving method
○ Load conditions (loading inertia, friction and cutting force)
○ Speed condition (maximum acceleration and velocity)
○ Duty cycle



Torque calculation
○ Calculate the torque corresponding to the speed under each operation condition
○ Calculate equivalent torque



Motor sizing and T-N curve confirmation
○ Select the appropriate motor from HIWIN's catalogue in accordance with calculated maximum torque, equivalent torque and speed.
○ Ensure the speed and the corresponding torque under all operating conditions are within the range of torque-speed curve of the motor.
○ Confirm the equivalent torque is within the continuous torque of the motor.

Torque Motor
T-N curve

■ Symbol

ϕ	Angular displacement (rad)	I_p	Peak current (A_{rms})
t	Moving time (sec)	I_e	Equivalent current (A_{rms})
α	Angular acceleration (rad/s^2)	I_c	Continuous current (A_{rms})
ω	Angular velocity (rad/s)	ω_0	Initial angular velocity (rad/s)
J_L	Load inertia (kgm^2)	m	Loading Mass (kg)
J	Rotor inertia (kgm^2)	R_L	Outside diameter of loading Mass (m)
T_p	Peak torque (Nm)	r_L	Inside diameter of loading Mass (m)
T_c	Continuous torque (Nm)	$a_L \cdot b_L$	Side length of loading Mass (m)
T_i	Inertia torque (Nm)	S	Distance from gravity center to rotary center (m)
K_t	Torque constant (Nm/A_{rms})		

STEP 1 Requirement

To select a proper motor, the following formula of load inertia and motion must be understood before selection.

Calculation of load inertia

Load inertia can be determined by 3D drawing software or the formula. Basic formula is as below:

moment of inertia of a hollow cylinder: $J_L = m \left(\frac{R_L^2 + r_L^2}{2} + S^2 \right)$

moment of inertia of a rectangular: $J_L = m \left(\frac{a_L^2 + b_L^2}{12} + S^2 \right)$

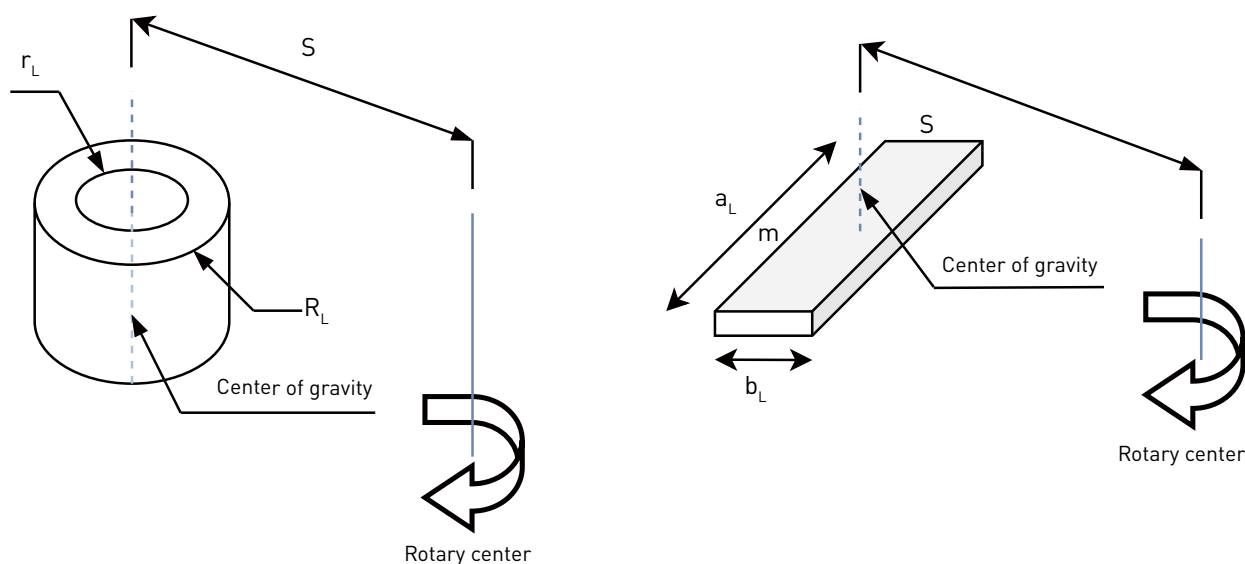

Determine motion speed and parameters

Basic kinematics equations are described as below:

$$\omega = \omega_0 + \alpha t \quad \phi = \omega_0 t + \frac{1}{2} \alpha t^2$$

Where ω is angular velocity, α is angular acceleration, t is moving time and ϕ is angular displacement. Users can choose two of the four parameters (ω , α , t and ϕ) as designed parameters. The left two parameters can be calculated by above equations.

※ Motion velocity profile

Motion profiles for torque motor can be classified into “Trapezoid profile” and “Triangle profile”. Trapezoid profile is usually used in scanning applications. Its motion profile can be divided into acceleration, constant velocity and deceleration. The maximum angular acceleration can be determined by the basic kinematics equations mentioned above. Triangle profile is usually used in point-to-point applications. Its motion profile can be divided into acceleration and deceleration, and its motion profile and formula can be simplified as below:

$$\omega_{max} = 2 \times \frac{\phi}{t} \text{ or } \omega_{max} = \sqrt{\alpha \times \phi}$$

$$\alpha_{max} = \frac{4\phi}{t^2}$$

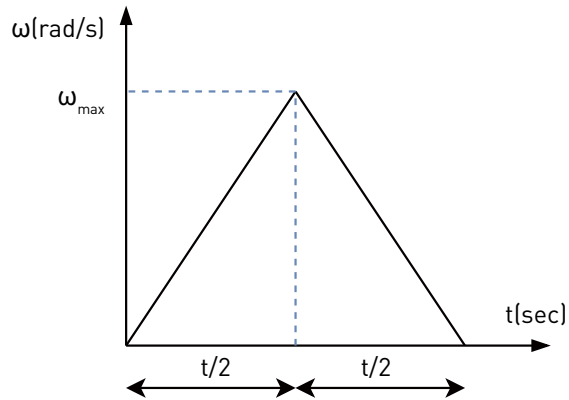

STEP 2 Torque Calculation

The maximum torque can be calculated by the following equation.

$$T_{max} = (J + J_L) \times \alpha_{max} + T_f = T_i + T_f$$

Where T_i is inertia torque, T_f is the torque caused by friction torque, cutting force or external force.

In most cases, the motions are cyclic point-to-point movements. The equivalent torque of a cyclic motion with a dwell time of t_4 second can be calculated as below:

$$T_e = \sqrt{\frac{(T_i + T_f)^2 \times t_1 + (T_i + T_f)^2 \times t_2 + (T_i - T_f)^2 \times t_3}{t_1 + t_2 + t_3 + t_4}}$$

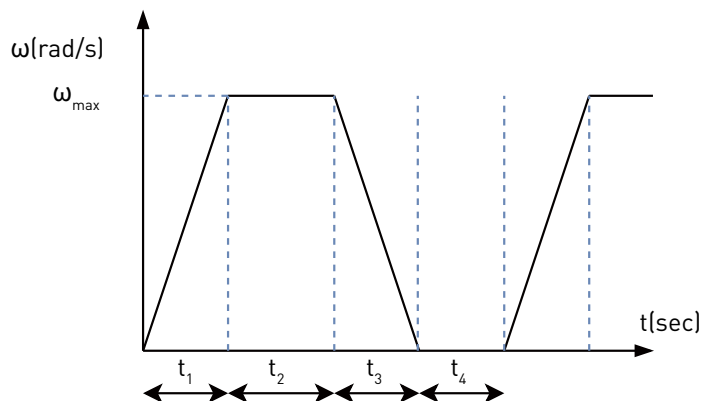

STEP 3 Motor Sizing and T-N Curve Confirmation

With the help of HIWIN's motor specification, users can select the appropriate motor from peak torque and equivalent torque, and ensure speed and torque under all operating conditions is within the range of the motor's T-N curve.

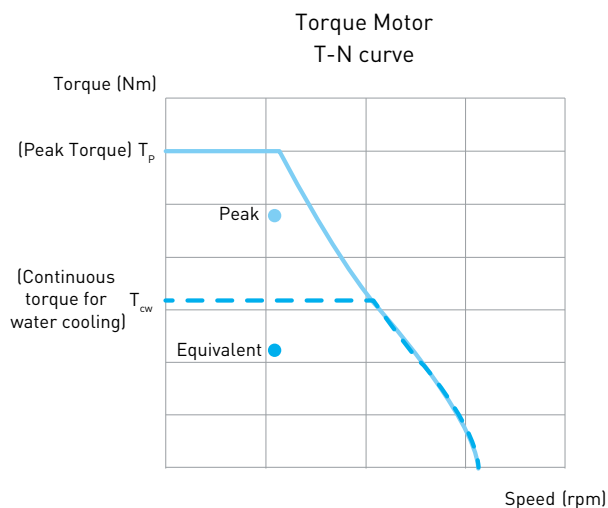

Motor sizing is determined as follows:

$$T_{max} < T_p$$

$$T_e < T_{cw}$$

Users need to consider the ratio of equivalent torque and continuous torque. Generally, the ratio (T_e/T_{cw}) is recommended to be within 0.7.

Note :

The torque-speed curve provided in the specification is for a specific voltage, regardless of the speed limit of the bearing and the position feedback system. The customer should also set the maximum speed limit of the overall mechanism when sizing to avoid bearing life or position feedback system failure result in abnormal operation or damage of the motor.

Appendix B: Glossary

- Back EMF constant (line-to-line): $K_v \left(\frac{V_{rms}}{rad/s} \right)$
 The back EMF constant, K_v , is the ratio of the back EMF voltage (V_{rms}) to the motor rotational speed (rad/s) when the magnet is at 25°C. It is created at the movement of the coil in the magnetic field of permanent magnets.
- Continuous current (WC): $I_{cw} (A_{rms})$
 The continuous current (WC), I_{cw} , is the current that can be continuously supplied to the motor coils at the water temperature 25°C, and the final temperature of coil can't exceed 130°C. Under this condition, the motor reaches the rating continuous torque (WC) T_{cw} .
- Continuous torque (WC): $T_{cw} (Nm)$
 The continuous torque (WC), T_{cw} , is the maximum torque the motor is able to generate continuously at the water temperature 25°C and the final temperature of coil can't exceed 130°C. The continuous torque (WC) corresponds to I_{cw} supplied to the motor.
- Inductance (line-to-line): $L (mH)$
 Inductance is defined as inductance measured between lines when the motor operates at the coil temperature 25°C.
- Resistance at 25°C (line-to-line): $R_{25} (\Omega)$
 Resistance is defined as resistance measured between lines when the motor operates at the coil temperature 25°C.
- Motor constant: $K_m \left(\frac{Nm}{\sqrt{W}} \right)$
 The motor constant, K_m , is defined as the ratio of motor output torque to square root of consumption power when the coils and magnets are at 25°C. The larger motor constant represents the lower power loss when the motor outputs at the specific torque.
- Number of poles: $2p$
 $2p$ represents the number of poles of the rotor, where p is the number of poles pair.
- Peak current: $I_p (A_{rms})$
 The peak current, I_p , is the current corresponding to torque output of the motor, and the motor temperature reached by current can't demagnetize magnet. Generally speaking, peak current can be granted to supply 1 second when the motor is operating in the normal condition and the input current phase is balanced. And then the motor needs to rest for at least 6 seconds after it reaches the normal temperature to supply peak current. (For more accurate time, please contact HIWIN)
- Peak torque: $T_p (Nm)$
 The peak torque, T_p , is the maximum torque that the motor outputs less than 1 second. Peak current corresponding to the torque cannot demagnetize magnet.
- Rotor inertia: $J (kgm^2)$
 The rotor inertia, J , is the rotary component resists any changes in its state of motion, including changes to its speed and direction. It is related to the shape and mass.
- Stall condition:
 When the motor is moving slowly with a control frequency bellowing 1Hz which is produced the uneven power distribution in the individual motor phases.
- Stall current (WC): $I_{sw} (A_{rms})$
 The stall current (WC), I_{sw} , is the upper limit of current when the motor is at the water temperature 25°C and in the stall condition.

- Stall torque (WC): T_{sw} (Nm)
The stall torque (WC), T_{sw} , is the upper limit of torque when the motor is at the water temperature 25°C and in the stall condition.
- Thermal resistance: R_{th} (K/W)
The thermal resistance, R_{th} , is defined as the resistance suffered heat from motor coil to dissipate the environment (for water cooling when the water is at 25°C). Higher thermal resistance represents the larger temperature difference between the coil and environment under the same heat source.
- Torque constant: K_t (Nm/A_{rms}) at magnet temperature of 25°C
The torque constant, K_t , is ratio between as the motor's output torque per RMS current. Output torque and input current shows a linear relationship when input current is low. The non-linear relationship is due to saturation in the iron core.

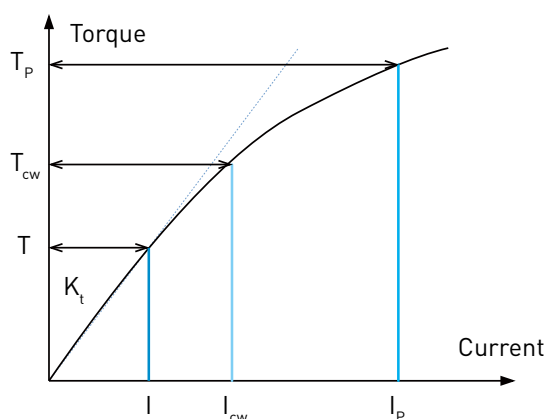

- Maximum speed (RPM):
Maximum speed is defined as maximum speed provided under specific torque (usually continuous torque). There are two conditions to define the maximum speed of torque motor: maximum speed under water-cooling continuous torque and maximum speed under peak torque.
- Maximum speed (Field Weakening) (RPM):
Maximum speed (Field Weakening) is defined as maximum speed in field weakening control, which is to weaken the magnetic field strength of the rotor magnets to reach higher speed, by applying an opposing magnetic field on the stator coils in phase with the rotor field. The field weakening control is only available for IM-2 series.
- Rated speed: ω_n (rpm)
Rated speed, ω_n , is defined as the speed at which the rotor will not be damaged due to the high temperature of the rotor (>80°C) caused by iron loss when the motor is running continuously without rest; if the speed exceeds this speed, the working cycle must be reduced or additional heat dissipation design must be conducted for rotor. Please refer to the T-N Curve for the explanation of the motor working range.
- T-N Curve (TM-2)
The T-N curve is defined as the comparison chart of the torque and the speed that can be output under a certain input voltage of the motor. Considering the temperature rise of the motor, the figure can be divided into four operating ranges as shown below:

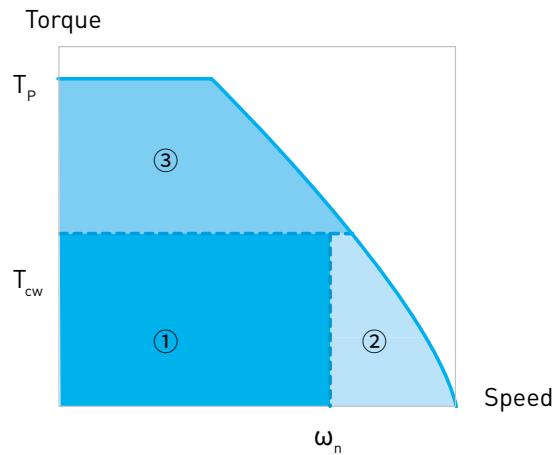

- ①: When the motor is water-cooled and the torque is less than T_{cw} , it can run continuously below ω_n without break.
 - ②: When the motor is water-cooled and the torque is less than T_{cw} , the speed is greater than ω_n , the duty cycle must be reduced or additional design on rotor heat dissipation must be provided to avoid overheating of the rotor.
 - ③: When the motor is water-cooled and the torque is greater than T_{cw} , the duty cycle must be reduced. When T_p is reached, only 1 second output is allowed to avoid overheating of the stator.
- * Due to the difference in the design of TM-2 and IM-2 motors, T-N curve of IM-2 will be slightly different from TM-2.

○ T-N Curve (IM-2)

The T-N curve is defined as the comparison chart of the torque and the speed that can be output under a certain input voltage of the motor. Considering the temperature rise of the motor, the figure can be divided into two operating ranges as shown below:

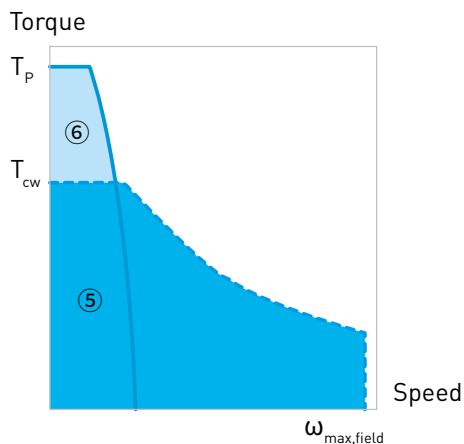

- ⑤: When the motor is water-cooled and the torque is less than T_{cw} , it can run continuously below maximum speed in field weakening without break.
- ⑥: When it is water-cooled and the torque is greater than T_{cw} , the duty cycle must be reduced. When T_p is reached, only 1 second output is allowed to avoid overheating of the stator.

- Maximum input voltage (V_{DC}):
Maximum input voltage is the maximum voltage for the motor operating in the normal environment.
- Maximum continuous power loss: P_c (W)
Maximum continuous power loss is the energy lost when the motor runs continuously under continuous current and the coil temperature is 130°C. It mainly converts into heat. In water cooling system, the loss is mostly eliminated by coolant.
- Maximum pressure difference: Δp (bar)
Maximum pressure difference is the maximum value tolerated by the pressure difference between inlet and outlet under water cooling system with pure water. It corresponds to minimum water flow q . If the operating environment is different, pressure difference must be modified by calculation (refer to torque motor installation manual).
- Minimum water flow: q (l/min)
Minimum water flow is the minimum flow required for normal cooling under water cooling system with pure water. If the operating environment is different, water flow must be modified by calculation (refer to torque motor installation manual).
- Temperature difference under maximum power loss: $\Delta\theta$ (°C)
Temperature difference under maximum power loss is the temperature difference between inlet and outlet under water cooling system with pure water. Generally, it is defined as 5°C. If the operating environment is different, temperature difference under maximum power loss must be modified by calculation (refer to torque motor installation manual).

Appendix C: Environment

Conditions	Environmental Parameter	Unit	Value
Operation	Air temperature	(°C)	+5~+40
	Relative humidity	(%)RH	5~85 (no condensation)
Storage/ Transport	Air temperature	(°C)	-5~40
	Relative humidity	(%)RH	5~85 (no condensation)
All	Atmosphere	Under 2000m, no corrosive gas, liquid and powder	

More information please refers to torque motor installation manual.

Appendix D : Motor Inquiry Form

Company Name:

Date:

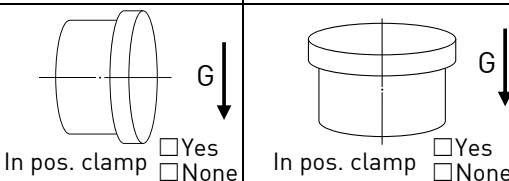
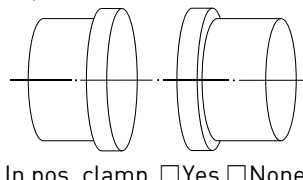
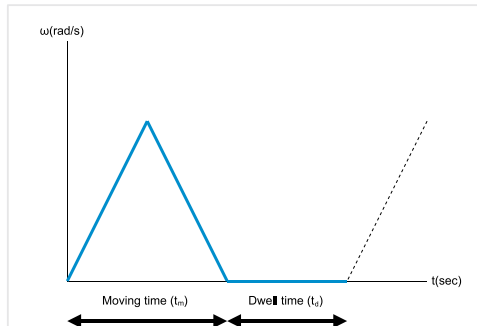
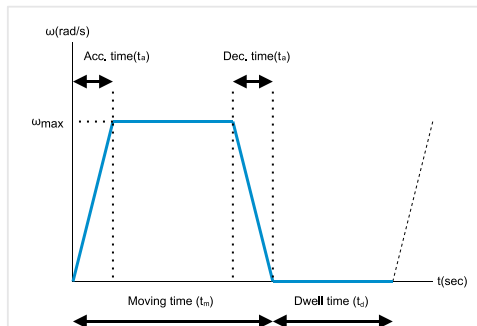
Email:		Contact Person:	
Tel:		Title:	
Fax:			
Industrial		10. Installation	<input type="checkbox"/> Single <input type="checkbox"/> Laterally <input type="checkbox"/> Horizontal
1. Environment	<input type="checkbox"/> Normal environment (25°C) <input type="checkbox"/> Other: _____		<input type="checkbox"/> Parallel operation (with one controller only) 
2. Load Type	<input type="checkbox"/> Water Cooling: ___ % (glycol) <input type="checkbox"/> Oil Cooling: Oil Type _____ Specific gravity: ___ g/cm ³ Specific heat capacity: ___ cal/g°C <input type="checkbox"/> Free-air convection: Ambient temp. ___ °C		
3. Load Conditions	<input type="checkbox"/> Total moment of inertia: _____ Kg·m ² <input type="checkbox"/> Load 1, qty _____ Mass: ___ Kg or Material: _____ Size: _____ mm Offset of C.G.: _____ mm <input type="checkbox"/> Load 2, qty _____ Mass: ___ Kg or Material: _____ Size: _____ mm Offset of C.G.: _____ mm <input type="checkbox"/> Load 3, qty _____ Mass: ___ Kg or Material: _____ Size: _____ mm Offset of C.G.: _____ mm	11. Motion Profile	a. <input type="checkbox"/> Triangle profile (Usually in P2P application) Moving angle (Φ): _____ Moving time (t _m): _____ Dwell time (t _d): _____ 
4. Friction Torque	<input type="checkbox"/> None <input type="checkbox"/> Yes: ___ Nm		b. <input type="checkbox"/> Trapezoid profile (Usually in "Scanning" or "Machining" application) Max. Speed (ω _{max}): _____ (Dec)Acceleration time (t _a): _____ Total moving time (t _m) or moving angle (Φ): _____ Dwell time (t _d): _____ 
5. Cutting Torque (External Torque)	<input type="checkbox"/> None <input type="checkbox"/> Yes: ___ Nm		
6. Controller	<input type="checkbox"/> Siemens <input type="checkbox"/> Heidenhain <input type="checkbox"/> Fanuc <input type="checkbox"/> Mitsubishi <input type="checkbox"/> Other _____		
7. Drive Voltage	<input type="checkbox"/> 200V <input type="checkbox"/> 380V <input type="checkbox"/> 400V <input type="checkbox"/> 565V <input type="checkbox"/> Other ___ V		
8. Drive Current	Rated ___ Arms Max. ___ Arms		
9. Cable Length	<input type="checkbox"/> Standard 2m <input type="checkbox"/> Other: ___ m (Max. Length ≤ 10m)		
Special Requirement:			

- The motors are all water-cooled design and verification. If it is oil-cooled or natural air-cooled, the actual condition of the machine needs to be monitored during operation.
- Choose one of the exercise conditions to fill in. If there are multiple application motion profiles, please fill in the most harsh conditions or contact HIWIN for assistance in evaluation.

Torque Motor Technical Information

Publication Date : June 2021, first edition

Print Date : June 2021, 1st edition

1. HIWIN is the registered trademark of HIWIN Group. For your protection, avoid buying counterfeit products from unknown sources.
 2. Actual products may differ from specifications and photos provided in this catalog. These differences may be the result of various factors including product improvements.
 3. HIWIN will not sell or export products or processes restricted under the "Foreign Trade Act" or related regulations. Export of restricted products should be approved by proper authorities in accordance with relevant laws and shall not be used to manufacture or develop nuclear, biochemical, missiles or other weapons.
-



Global Sales And Customer Service Site

HIWIN GmbH

OFFENBURG, GERMANY
www.hiwin.de
www.hiwin.eu
info@hiwin.de

HIWIN JAPAN

KOBE · TOKYO · NAGOYA · NAGANO ·
TOHOKU · SHIZUOKA · HOKURIKU ·
HIROSHIMA · FUKUOKA · KUMAMOTO,
JAPAN
www.hiwin.co.jp
info@hiwin.co.jp

HIWIN USA

CHICAGO, U.S.A.
www.hiwin.us
info@hiwin.com

HIWIN Srl

BRUGHERIO, ITALY
www.hiwin.it
info@hiwin.it

HIWIN Schweiz GmbH

JONA, SWITZERLAND
www.hiwin.ch
info@hiwin.ch

HIWIN s.r.o.

BRNO, CZECH REPUBLIC
www.hiwin.cz
info@hiwin.cz

HIWIN FRANCE

STRASBOURG, FRANCE
www.hiwin.fr
info@hiwin.de

HIWIN SINGAPORE

SINGAPORE
www.hiwin.sg
info@hiwin.sg

HIWIN KOREA

SUWON · CHANGWON, KOREA
www.hiwin.kr
info@hiwin.kr

HIWIN CHINA

SUZHOU, CHINA
www.hiwin.cn
info@hiwin.cn

Mega-Fabs Motion Systems, Ltd.

HAIFA, ISRAEL
www.mega-fabs.com
info@mega-fabs.com

HIWIN MIKROSYSTEM CORP.

No.6, Jingke Central Rd.,
Taichung Precision Machinery Park,
Taichung 40852, Taiwan
Tel: +886-4-23550110
Fax: +886-4-23550123
www.hiwinmikro.tw
business@hiwinmikro.tw