

UNCONTROLLED IF PRINTED

$\sqrt{Ra6.3}$ ($\sqrt{Ra0.4}$)

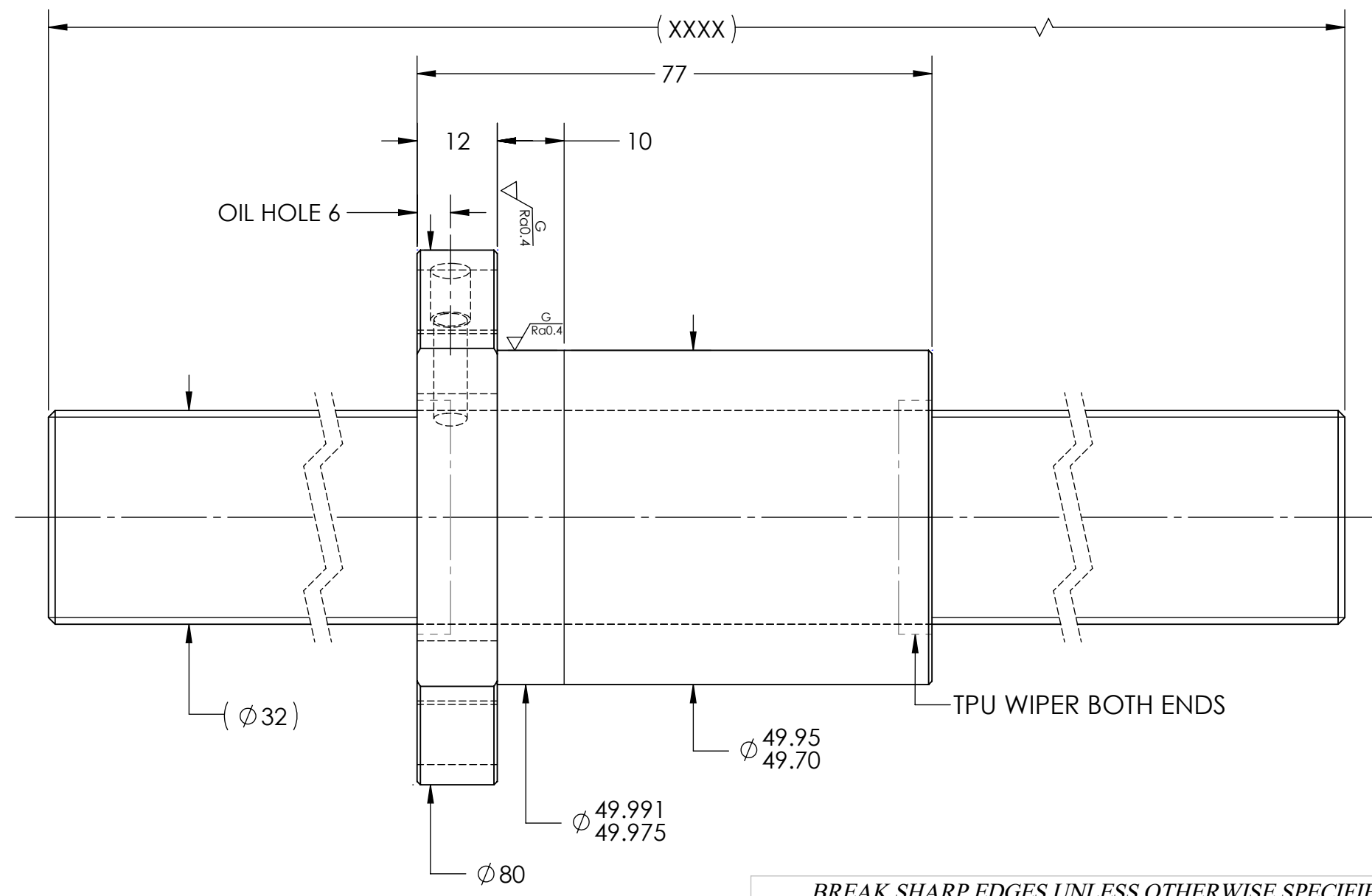
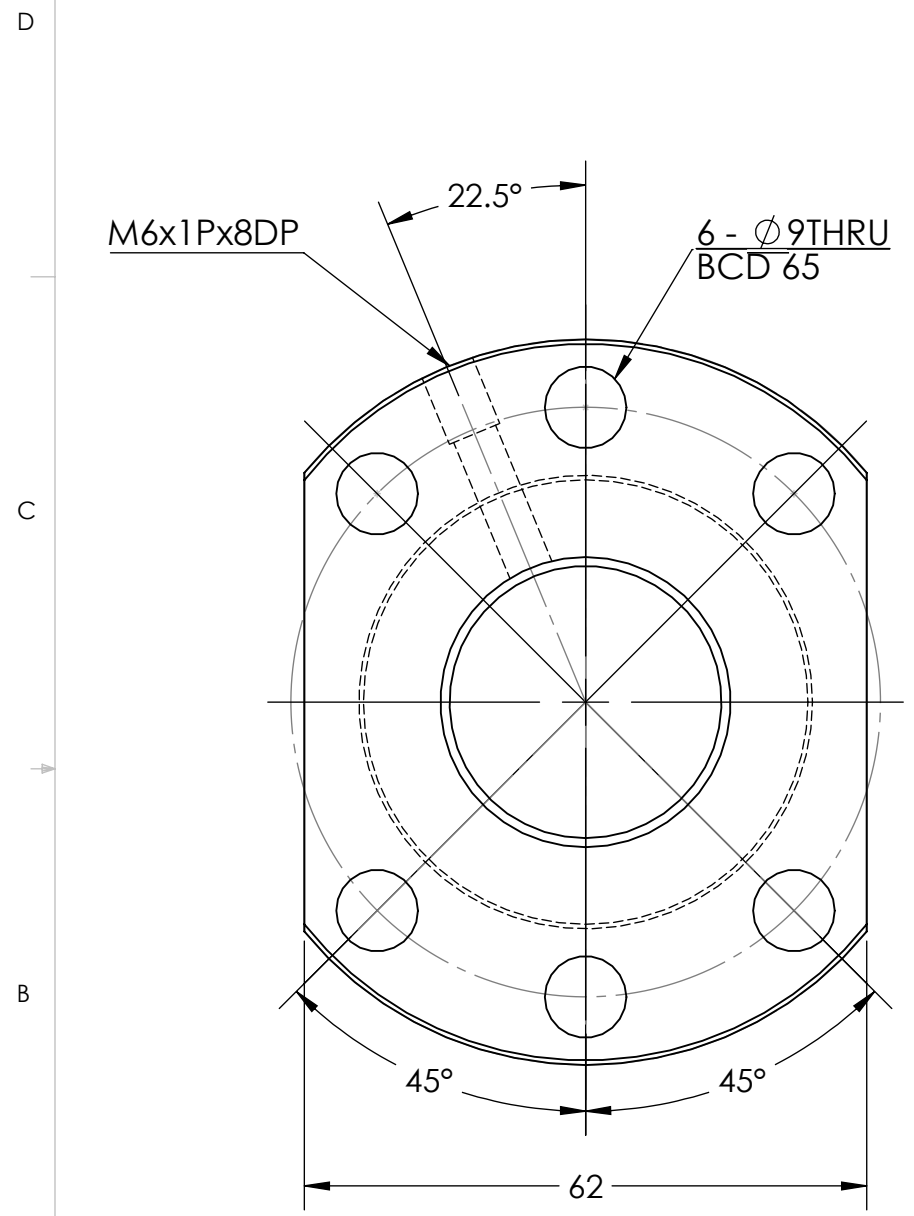

BREAK SHARP EDGES UNLESS OTHERWISE SPECIFIED

ROUGH M/C	FIN M/C	GRD		MATERIAL	SHAFT:CF53/Equiv. NUT:SNM220/Equiv.
$\sqrt{Ra25}$	$\sqrt{Ra6.3}$	$\sqrt{Ra0.4}$		THREAD BALL TRACK	HRC 56-62

TOLERANCE mm

UP	6	30	120	300	600	1200	2400	2400	
TO	6	30	120	300	600	1200	2400	OVER	
TURN DIRECTION	R	± 0.1	± 0.2	± 0.3	± 0.4	± 0.5	± 0.8	± 1.0	± 1.5

PRELOAD(kgf)	~	DATE	INITIALS	 HIWIN CORPORATION 12455 Jim Dhamer Dr, Huntley, IL 60142		
R.D.	27.424	DRAWN	11/21/2022		D.W	
S.F. (kgf)	~	CHECKED	01/18/2023		T.C.	
DRAG TRQ(kgf-cm)	~	MFG APPR.	01/18/2023		A.H	
TURN DIRECTION	R					
P.C. DIA.	31.48	TITLE: STANDARD STOCK BALLSCREW				
BALL DIA.	3.969	PART NUMBER: R32-10K5-FSCEW-XXXX-XXXX-0.05				
BACKLASH	0.03 MAX	SIZE	DWG. NO.	REV	SCALE	NTS
CIRCUIT	5	B	W-SBS-32-10-A02	N/C		
LEAD ANGLE	5.77	v300p:				
DYNAMIC (kgf)	3390					
STATIC (kgf)	8160					
LEAD	10					

HIWIN CONFIDENTIAL